

**TOWN OF WELAKA**  
**REGULAR TOWN COUNCIL MEETING**

March 12, 2024, at 6:00 PM

Honorable Willie Washington, Jr. Town Council Room  
400 4<sup>th</sup> Avenue, Welaka, FL 32193

*(This meeting will be broadcasted, for view only, on the Town of Welaka's Facebook Page)*

- 1. CALL TO ORDER**
- 2. PLEDGE OF ALLEGIANCE & INVOCATION**
- 3. ROLL CALL BY TOWN CLERK, Meghan Allmon**
- 4. ADOPTION OF PREVIOUS MINUTES:** February 13, 2024, Regular Meeting Minutes
- 5. APPROVAL OF CURRENT AGENDA**
- 6. RECOGNITIONS**
  1. Tyler Buford - Distribution 3 License passed on March 1, 2024
- 7. PRESENTATIONS / REPORTS TO TOWN COUNCIL**
  1. Discussion of former employee discrimination allegations
  2. Events Committee
  3. Citizens Advisory Committee
  4. Tree Board

*Presentations are scheduled by individuals or businesses to inform the Town Council of issues, projects, etc. The Council shall not take formal action upon issues or matters presented under presentations at the same meeting. If formal action is desired, such matters shall be deferred and scheduled for a subsequent or future Council Meeting for consideration. Council may, however, by a majority vote, act on items they deem necessary and appropriate. Items not requiring Council action shall be directed to the mayor for consideration and further action.*

- 8. PROCLAMATIONS**
  1. PROC 2024-02 - March is National Women's History Month
- 9. RESOLUTIONS - None.**
- 10. PUBLIC HEARINGS**
  1. ORD 2024-02 Tree Ordinance (Update of ORD 2015-01) First Reading
- 11. CORRESPONDENCES**
  1. None.
- 12. PUBLIC COMMENTS**
  - a. Request To Speak - David Jeltis

*A 'Request To Speak Form' shall be completed and submitted to the Town Clerk to officially address the Town Council. There will be no response to the speaker by Council or Town Staff, except the Council Members desiring to address a comment made during this part of the meeting may do so under Section 13 of this section. One specific issue per Form may be submitted, and you will have up to 3 minutes to address the Council.*

**13. CONSENT AGENDA ITEMS - None.**

**14. NON-CONSENT AGENDA ITEMS**

**1. TOWN MATTERS**

- a. Approval of sewer pumps for Utility
- b. Approval of lawn mowers for Public Works
- c. Approval of carport for Tractor

**2. ZONING BOARD**

**3. CODE ENFORCEMENT BOARD**

- a. Code Enforcement Officer / Zoning Tech needed

**15. DEPARTMENT REPORTS**

**1. PUBLIC WORKS DEPARTMENT REPORT**

**2. UTILITY DEPARTMENT REPORT**

**3. POLICE CHIEF MICHAEL PORATH REPORT**

**4. TOWN ATTORNEY PATRICK KENNEDY REPORT**

- a. ORD 2024-01 No Wake Zone Discussion
- b. Town purchased 640 Palmetto Street, demolition can start now

**5. TOWN CLERK MEGHAN ALLMON REPORT**

**16. MAYOR & TOWN COUNCIL REPORTS**

**1. MAYOR WATTS**

**2. COUNCIL PRESIDENT JESSICA FINCH**

**3. COUNCILWOMAN TONYA LONG**

**4. COUNCILWOMAN KATHY WASHINGTON**

**5. COUNCILWOMAN KIMBERLY DUGGER**

**17. ADJOURNED**

**TOWN OF WELAKA TOWN COUNCIL MEETING**  
**February 13, 2024, 6:00 PM**  
**Honorable Willie Washington, Jr. Council Room**  
**400 4th Ave., Welaka FL 32193**

**MINUTES**

*(This meeting was broadcasted for view only on the Town of Welaka's Facebook page)*

1. Mayor called Meeting to order at 6:00 PM.

2. Everyone stood and said the pledge of allegiance and Washington gave the invocation.

3. **ROLL CALL** taken by Town Clerk, Meghan Allmon.

Mayor Jamie Watts - present, Council President Jessica Finch - present, Councilwoman Kimberly Dugger - present, Councilwoman Kathy Washington - present, Councilwoman Tonya Long - present, and Town Attorney Patrick Kennedy - present. Five council members are present. We have a quorum.

4. **ADOPTION OF PREVIOUS MINUTES from 1/23/2024 MEETING**

Corrections – None.

Motion to adopt 1/23/2024 Town Council Meeting Minutes made by Finch and seconded by Washington. Passed 5/0.

5. **APPROVAL OF CURRENT AGENDA**

Correction – Watts moved the 13.1. and 2. Items from the original Agenda down to #14. as Non-Consent Agenda Items. The items moved were:

1. Bid review and selection of contractor for forced main sewer repair
2. Preliminary Boundaries for the Finding of Necessity

Motion for approval to accept current 2/13/2024 Town Council Meeting Agenda made by Finch and seconded by Long. Passed 5/0.

6. **RECOGNITIONS** – None.

7. **PRESENTATIONS / REPORTS TO TOWN COUNCIL**

1. Diane Kelley - Mobile Spay and Neuter Program

She met with the surrounding Mayors about the animal spay/neuter service in the county. A new location is trying to be established and she supports this. She handed out copies of her presentation to the Council Members. Animal Rescue Konsortium has been around since 2007. The rescue facility is in Crescent City as the Crescent City Kennel. Animals in distress are helped there. Ginny, the owner, wants to evolve ARC. We do not have a low cost spay/neuter facility. Shelters have major capacity issues.

She'd like Welaka to establish a partnership with the Town.

Animal overpopulation is a big issue. Most dog bites and killings come from un-neutered male dogs.

They're working on a grant to get a spay/neuter trailer with actual vets to perform the surgeries. A grant would fund 75% of the estimated range from \$125,000 - \$200,000 for a trailer.

Her and Ginny would also like to have the building modified for the ability to help more animals. This would be around \$42,000.

Putnam County approved \$25,000 as a donation towards their goals and grant funding. She documented their

commitment to them. They're left with \$15,000 or so that they need. She says it's not a donation, it's an investment. Would Welaka be open to contribute? They'll also be meeting with Crescent City again and Pomona Park and the city of Palatka. The ARC pays for all the medication.

Watts – his dog was neutered a few months ago and it cost almost \$400. Asked Diane if the mobile trailer would be coming to Welaka?

Diane - said she'd talk to Ginny and was sure she'd happily approve of this, and they could give vouchers and big discounts. Sometimes she would do it for free if someone cannot afford it in a critical situation. A few key locations here can be added. Ginny agreed up to 70 cats/dog quarterly (280 per year) with charging a good-faith-fee of \$45 per dog and \$35 for a cat. They also offer discounted vaccination shots.

Watts – would like to bring this back to the Council for a one-time investment.

Finch – her goal is 100 per year since 2018. A lot of cats are dropped off here. Wants to see a list of the county's request sheet. How many can you spay/neuter in 1 day?

Diane – It's like an assembly line and around 20-30 animals per day and she can send a summary.

Finch – cost?

Diane - \$80-90 for the biggest dog and she'll get his in writing after speaking with Ginny and send it to Finch.

Finch – 2 dates per month? Would that expand?

Diane – that's for the clinic in Crescent City. Once demand is reached, they can schedule more visits here. They have 2 vets available. Ginny wants to evolve this for the main service in Putnam County.

Finch – would like more information and this would help her service for spay/neutering here in Welaka.

Washington – on call vet in case something happens after the surgery?

Dinae – not sure. Could be a number for the ER. They're not down to that level of detail.

Washington – some vets don't want to touch another dog after a different vet.

Watts – if she sends us some info, we can discuss this ORD with the Council again next month and hopefully have an updated map by then. It will not be a second reading.

2. Events Committee – None.

3. Citizens Advisory Committee – None.

8. **PROCLAMATIONS** – None.

9. **RESOLUTIONS** – None.

10. **PUBLIC HEARINGS**

1. **ORDINANCE 2024-01 – Welaka No Wake Zone (First Reading)**

Advisory Committee asked about this, so he put this ORD together last month. It provides for a maximum distance of 500 feet from the shoreline. The GIS is helping him to fine-tune the mapping.

Long – not comfortable with this at all. She wants to speak to people and it's not at her level to make this decision.

Washington – when we have the bass tournaments, and we have a lot of people who are flying down the river. Will this effect that, or no?

Kennedy – may not affect them if they're in the channel.

Washington – who will enforce this? Do we call the police for boats speeding?

Kennedy – you would have to ask Chief and a boat speeding would have to be seen to be pulled over. He did not include a summary paragraph and he will fix that.

Porath – mutual aid agreement, not sure if the County or FWC will enforce a Town Ordinance. We would need a mutual aid agreement that defines this. Both agencies would like to add more patrol on the river. Even if we had

a boat, and someone called in to report a crime, they would have to address the operator if they could find them. Not sure if the County would adopt our ORD to enforce it.

Kennedy – the FWC rep said that if our ORD is good enough, they would enforce it.

Porath – they will refer to state law and he agrees with the Council, we can have laws, but if we don't enforce the law, then take it off the books.

Washington – spoke with a few boaters and if there's a wake, then they said they just wait for the waves to go by. There's not a problem.

Watts – our floating dock was not maintained properly, and it cost \$17,000 in repairs. He's not comfortable moving forward with this until we get the boundaries.

Turnbull – FWC required that we get an ORD in order to move forward with this.

Finch – just because it's not going to be enforced at all times, we should still put out what we want to see. It would give boaters notice. We're just talking about a few hundred feet from the boat ramps, not out into the channel. Common courtesy is out there and sometimes not. This will bring awareness to hurting our docks and boat ramp issues.

Dugger – agrees with Finch. Thinks a good ORD and it's a good start. Just the existence of this ORD and for our waterfront property owners, they will appreciate this. How can this hurt us? It will be a good thing to have.

Finch – people would mostly only be speeding by in the channel. Wouldn't want the dock repairs to come back 2 years from now when we're out of ARPA funds.

Watts – asked Kennedy to flush this ORD out and move it to next month.

Washington – is it verified that the dock needed repair from the wakes or just wear and tear because nothing lasts forever?

Watts – the wakes hitting the dock and the steel rods worked their way out and it was poor maintenance.

Bellingham Marine showed us how to tighten it down.

Watts – postpone this ORD and update the map.

Washington – bass tournaments have an exception?

Kenneth Pagano – as far as the bass tournament, if the Elite Team that comes to town in April, if it's sanctioned and they fly through a no-wake zone, they're disqualified. South Lake George has no wake and then idle and so on. There're rules all the way down to Deland. If you create a No Wake zone, there's no complaints on the water as he's on his boat a lot. FWC pulls a lot of people over. Whether you're driving or speeding, it creates the same size wakes. Some creeks and canals you must go idle speed. If this ORD cannot extend all the way across the river, wakes will still affect you the same. The rubber on the dock is not too good and it will destroy your gel coat. Big boats going 10 MPH still put off a 2' wake.

Felicia Stalder – who owns the boat ramp?

Watts – we found the records and Welaka owns the boat ramp.

Stalder – is the boat ramp road going to be repaired?

Watts – not yet, we must generate the funds to do so.

## **11. CORRESPONDENCES**

### **1. Mayor Watts - Memo to Council on 2/7/24 - Utility Billing Issue**

Watts – takes full responsibility for this overcharge and he should have gone through the bills first before sending them out.

Washington – how will this be handled for the next couple months?

Watts – the Utility Clerk will round each bill down manually.

Dugger – same with in-city and out-of-city people?

Watts – correct. Our software program, Logics, said that we cannot pro-rate the gallons, but we can pro-rate the days. Makes no sense.

Long – can we go in and set the gallons at 3,000 possibly? This will take away all the people that use no more than 3,000 gallons.

Watts – she can possibly do this but the credits that she is manually doing now will be more accurate.

Washington – some people’s bills doubled and are there leaks or something?

Watts – if anyone suspects a utility issue, call us to schedule our utility crew to go check it. In the future, the auto-read meters will monitor the flow, and it will automatically alert the system telling us of continued flow meaning a leak. We can do a bucket test and they can read the meter and will put 5 gallons in the bucket to see if the meter is reading properly showing 5 gallons used. You are not charged for that 5 gallons either.

Watts – we were doing courtesy calls for prospective leaks.

Clemons – it shouldn’t be referred to Emma, it should be sent to Tyler. He went from 3,000 to 11,000 gallons. He’s not arguing about the water, but he would have been able to fix a leak if he knew about it with a courtesy call. Or do a door hanger if possible.

Watts – we’re looking into this.

Clemons – will not argue, it’s just a courtesy. This should flash red on the computer to let the utility meter reader know and they should notify that resident, Emma should not have to.

Watts – we’re going to work on this and make sure our staff does not get cussed out for this.

Finch – the guys see that there is excessive usage and they can hang a door hanger on the residence.

Clemons – Emma just sees the numbers.

Watts – he’s trying to rotate the books through.

## **12. PUBLIC COMMENTS**

Greg Clemons – 601 Oak Street – addressed the water notice courtesy calls. He had a leak and wasn’t notified. Watts said that we discontinued doing courtesy calls as people were not thankful but rather would attack the Utility Clerk and respond negatively.

Janet Smith – 60 Carefree Drive – addressed her concern about the water rate increase. The wake issue can be horrendous injuries on boats and down in the engine area. It’s more than just properties.

The overage charges – this is meant to be cordial regarding the water charges. There are serious maintenance issues and yet the best government is fair to the residents. Raising base rates plus lowering the gallon limit all in one hike is problematic. The surcharges are more likely to be monthly applied to a much larger water bill.

Wasn’t told the criteria about 2,000 gallons for a household. THE St. Johns River Water Management District report per capita use is 115 gallons per day, at the previous 3,000 threshold, it was over 400 gallons less. If local info used to gather the 2,000 minimal thresholds, was any hot season, love bugs, ash, pollen seasons a part of the low or high water/sewer months? Also, hurricane seasons create a sludge from the neighboring properties after the hurricanes. Requires more work and water after the floods. The automatic readers will be in the future, not known when. Please keep in mind that there’s a lot of seniors on a fixed income here and it’s difficult. Is the FL public service commission notified?

Watts – they do not have to be notified as we’re a municipality.

Smith – if the issue is repairs, then everyone should be charged per gallon, and they’re tied to surcharges.

There’s no incentive to conserve if someone has not used their minimal 2,000 gallons. We should not continue with this arbitrary 2,000 minimal threshold. The limit is improper, and we should go back to the 3,000 gallons.

Watts – of the 724 customer, 399 did not exceed 2,000 gallons this past month. More than half.

Cynthia Washington – the summer when the storms come, when you’re using the water, the rate goes up. She uses her water pump, and it helps some. When there’s mildew on homes, can’t clean them. Wants to increase back to 3,000 gallons.

Watts – hasn’t been increased since 2012. The \$1.8 Million Dollars of repairs is needed. If we kept it at 3,000 gallons, we’d have to raise the rate higher. We are higher than St. Johns County because we have a small Town.

The cost of repairing our system keeps increasing.

Finch – if we raise it to 3,000, it would be the same minimal as it is now, but it would be the increased as well. It's not fair for the elderly or smaller home to pay the minimal of 3,000-gallon bill.

Lenore Toole – river park is 3,000 gallons and their bill is around \$68. We do not have the highest funds around. We are very reasonable rated.

Finch – the average was 2,000 gallons.

Watts – wanted to verify this before the rate increase was presented.

Clemons – a person with 2-4-4 kids, this number is 2,000-gallon number is too low for a family household.

Finch – we'd be subsidizing and the fair way would be a per gallon rate.

Washington – literally everybody's water bill basically doubled and some tripled. Even hers. Felt blind-sided. If she went 1 or 10 gallons over, now she went over, the old way of charging was per 200 and the credits are the main concern, and this isn't what we talked about.

Finch – asked people who called her if their usage dramatically changed. Now with the proration thing solved, this is helpful.

Zarka Wynn – people who are on the bulk rate, Lazy Days, and the condos.

Watts – they're being applied the new rate, and the minimal rates went up like everybody else. Their usage went down and once they cross a certain threshold, they will get billed additionally.

Watts – out of town residents pay 25% more as a surcharge. There's a bill in the House right now and if that goes away, we will have to charge the additional 25% and affect us.

Bob Trevor – if he uses 2,001 gallons how does it roll?

Watts – right now, if you use 2,900, it rolls down to 2,000.

Mr. Smith – to wash some cars or fill a pool or use water and not sewer, it's too expensive to pay the \$20 fee to have your meter read prior.

Patricia – rates continue to go up next year?

Watts – yes.

Long – as we grow, River Hill, 1<sup>st</sup> Street, etc. we'll have more residents here to help offset this. When she has a bigger event, she'll put a porta-potty out front to save money on the water/sewer fees.

Desouza – the event committee still has cupcakes/coffee/cocoa inside here.

Pam Washington – Long stated that we're going to grow and what if it doesn't? Will the rate still go up?

Long – after 24 months, we should do a rate study and we can hopefully apply for grants. If you have a visitor over Christmas, the new rates have made it so expensive.

Watts – the prices go up on all supplies/labor. This is why we need a Town Manager to assist with this.

Pam Washington – she was the first meter maid. Mr. Clemons understands the utility system and a door hanger would help.

### **13. CONSENT AGENDA ITEMS**

1. Bid review and selection of contractor for forced main sewer repair (Watts corrected and moved down to # 14.1.)

2. Preliminary Boundaries for the Finding of Necessity (Watts corrected and moved down to # 14.2.)

### **14. NON-CONSENT AGENDA ITEMS**

#### **1. TOWN MATTERS**

1. Bid review and selection of contractor for forced main sewer repair - Watts corrected and moved down to # 14.

Watts – received 2 quotes for repairs of the underground pipes that exploded. We have approximately \$91,000 in ARPA left. He suggests we pull it from ARPA. Had a meeting with FEMA on Monday. We're receiving

\$87,023.50 in reimbursements from FEMA for Hurricane Ian damages. Trying to avoid damaged parts especially since storm season is coming. We must make the repairs and we can be reimbursed by ARPA. \$30,388 is needed for the needed repairs. We are creating the Asset Management Fund this month also from the rate increase to save money for repairs like this.

Watts – showed 8 photos on the TV screen of the manhole damages and flowing sewage onto the street from the 6” pipe going into a 2” pipe. A poor fix years ago to just get by.

Finch – what you said makes perfect sense.

Finch made a motion to approve the PBM Constructors Quote using ARPA Funds not to exceed \$54,000 and Dugger seconded. Passed 5/0.

Washington – warranty from this company?

Watts – yes, believes it’s 1 year and they’ll fix any repairs, and they stand behind their work. We’ve used PBM in the Sportsman Harbor area in the past. They’ve been in business for 40 years or more.

All Agreed. Passed 5/0.

Watts – these purchases are not going to be made, but I need the Council’s approval to approve up to the amount on the AIRVAC quote, up to \$30,383.20 amount.

Washington – is this the Harbor damage?

Watts – yes.

Finch – we will get reimbursed from FEMA.

Watts – correct.

Dugger made a motion to approve the Mayor to use up to \$30,383.20 for the Town’s utility repairs and Finch seconded. Passed 5/0.

## **2. Preliminary Boundaries for the Finding of Necessity - Watts corrected and moved down to # 14.**

Kennedy – cannot do CRA outside the Town limits. This was explained in the Workshop also. The map highlights the CRA area in blue. It focuses on the business districts and commercial corridors, all of Shell Street and includes the condition of roadways.

Watts – asked Kennedy to explain what the CRA is.

Kennedy – it is designed for economic growth and funding for the Town areas that need help. We take a portion of the property taxes with increasing property values and save it to put into the CRA. Over time it generates a funding account. We don’t want to include too much or too little. The more commercial properties, the better.

These are the larger property tax base locations. The CRA is the core of our Town. This area supports the Finding of Necessity. It may take Kennedy 60-90 days to have the paperwork ready for review.

Washington – is it the blue area on the map?

Kennedy – yes.

Finch – we can recoup some of the County’s property tax portion also.

Watts – just to let everyone know, this does not increase your property taxes here.

## **3. Tree ORD Public Workshop - Feb 20, 2024, 6-8 PM**

Pagano - It may be postponed but will let us know.

Dugger – Phillip Purcell is willing to donate 100 live oaks for 2<sup>nd</sup> Avenue, across Boston and across Mill St.

Dugger will send Kenny Philip’s info to chat.

Pagano – seems informal right now and will contact the utility department to see where trees can be planted on easements. Would like to add this to the Tree Board Meeting Agenda for 2/22/24.

## **4. Vulnerability Assessment Meeting to be Rescheduled.**



Watts – waiting for Saltus to get with us to reschedule this. We could not have the meeting due to having no power that evening. If you have flooding issues, please come to this meeting with pictures to show and create an overall image of the total flooding area so we can create a plan.

**2. ZONING RECOMMENDATIONS** – None.

**3. CODE ENFORCEMENT BOARD** – None.

## **15. DEPARTMENT REPORTS**

**1. PUBLIC WORKS DEPARTMENT REPORT** – None.

**2. UTILITY DEPARTMENT REPORT** – None.

### **3. POLICE CHIEF MICHAEL PORATH REPORTS**

Porath – 11/15/24, there was a complaint and he requested FPL to come out and there’s a delay in the parts to get the light issue resolved. It has been escalated now and hoping to have this resolved by next month.

On Orange, Washington addressed a resident that possibly Porath can add the pole light to this request.

Watts – closing the parks at sunset, we don’t want the parks completely dark due to vandalism, maybe we can scale all the lights back.

Porath – will work with Public Works to assist with the lights.

### **4. TOWN ATTORNEY PATRICK KENNEDY REPORTS**

Kennedy – need to schedule a Special Meeting to present the Land Development Code from the Zoning Board. The goal is not to make too many changes, but some are necessary. There’s been several changes since 1983 and they’ve reviewed and combined Ordinances. Accessories and structures are addressed. Wants the Council to understand the ORD.

Needs 2 weeks to properly public notice this.

Watts – all agreed to schedule a Special Called Town Council Meeting on 3/5/24 at 6 PM.

Kennedy – it should be 2 hours or so. Palatka Daily News will publish this also.

**5. TOWN CLERK MEGHAN ALLMON REPORTS** – None.

## **15. MAYOR & TOWN COUNCIL REPORTS**

**1. MAYOR WATTS** – DEP Meeting in the morning. The Harbor system is very old and it does not properly convert to a new system currently. The repair for this is to put a new system in it. The price for this is \$4.96 Million Dollars. The DEP is willing to let Watts pitch this project to them.

Plastic pods would be inserted in the Harbor area and the system would be completely sealed up.

On a dry day, the WWTP processes 50,000 gallons per day and on a rainy day, it increases to 125,000 per day. It’s a lot of rain/river water.

Washington – does the County help with any of this payment because they’re down there too.

Watts – with everything, we’d be over \$19,000 in grants. We’re working on the new WWTP designs will be at 90% in March on the drawings, Auto-Read Meters, Lift Station 6 rehab, 2 FRDAP grants. FL Budget was \$118 Billion last year, and the governor wants \$4 Billion cut off that. The Legislators funded everything last year.

**2. COUNCIL PRESIDENT JESSICA FINCH** – None.

**3. COUNCILWOMAN TONYA LONG** – None.

**4. COUNCILWOMAN KATHY WASHINGTON** – went to a leadership class for FLC. It was about 5 classes and she sat in on 1 class. She chose Emergencies for small Towns. What are the challenges that local officials deal with? Hurricanes, fires, and active shooters. She faced panic and communications. What about our elderly residents? She left home with the controlled burning and came home to a lot of ash. What procedure do we have here for an evacuation route? She was concerned that we don't have it in black and white. The Hawaii fires got out of control easily. Welaka will deal with fires more than hurricanes. She's going to be on the punch with this to have something in black and white to notify our residents and she will bring this back to the Council. Watts – good project for you. The Chief can assist you also. The County has the list of non-mobile residents. It's not a public record, but maybe you can look into this to help. There were fires in 1996 and they were getting too close. The controlled burns help with this. We do need some plans and communications for this. Please look to the Chief for some assistance.

**5. COUNCILWOMAN KIMBERLY DUGGER** – Annexation, it's a dirty word and nobody wants to talk about it. Welaka will continue to limp along. We're strapped for money. People say we can't annex, it's too long and expensive. Yes, we can, we can do it. Let's annex in Sportsman Harbor as we cannot continue to go on with our Town as inequitable as we are. We've got to fix this. She's going to devote herself to do these annexation steps with the county and residents. Watts – thank you for taking this project on.

Pamel Washington – worked for the county for 29 years. The residents did not want to annex in and it's up to the residents and not the Town. Start talking with the residents.

Dugger – she has and agrees that some do not want to annex in. The Legislature can passed a bill where it's required.

Pam Washington – Larry Pritchett doesn't want to do this, they do not want this, but go speak to them.

Finch – of course they like it, they get the benefits and don't have to pay for it.

Watts – we could suggest annexation for utility services.

Dugger – Melbourne and other areas require annexation.

**16. ADJOURNED** – 8:31 PM



# Town of Welaka Proclamation 2024-02

## Proclamation for the Month Of March as Women's History Month

**Whereas**, every year, the President issues a special Women's History Month Proclamation.

**Whereas**, Whereas American women of every race, class, and ethnic background have made historic contributions to the growth and strength of our Nation in countless recorded and unrecorded ways;

**Whereas**, American women have played and continue to play critical economic, cultural, and social role in every sphere of the life of the Nation by constituting a significant portion of the labor force working inside and outside of the home;

**Whereas**, American women have played a unique role throughout the history of the Nation by providing the majority of the volunteer labor force of the Nation;

**Whereas**, American women were particularly important in the establishment of early charitable, philanthropic, and cultural institutions in our Nation;

**Whereas**, American women of every race, class, and ethnic background served as early leaders in the forefront of every major progressive social change movement;

**Whereas**, American women have served our country courageously in the military;

**Whereas**, American women have been leaders, not only in securing their own rights of suffrage and equal opportunity, but also in the abolitionist movement, the emancipation movement, the industrial labor movement, the civil rights movement, and other movements, especially the peace movement, which create a more fair and just society for all; and

**Whereas**, despite these contributions, the role of American women in history has been consistently overlooked and undervalued, in the literature, teaching and study of American history:

**Whereas**, this resolution was passed by Congress in 1987 and successive years since then.

**Now, Therefore, be it resolved** by the Town of Welaka and the Senate and House of Representatives of the United States of America in Congress assembled, that March is designated as "Women's History Month."

Jamie D. Watts, Mayor



Notes on editing:  
Strikeouts are deletions.  
Colored text is additions.  
Highlighted texts are associated with comments.  
For comments marked "LEGAL" Board requests additional review from Attorney.

**ORDINANCE 2015-1  
WELAKA TREE ORDINANCE**

**AN ORDINANCE PROVIDING FOR CARE, NURTURING, AND REPLACEMENT OF TREES AND SHRUBS WITHIN THE  
TOWN OF WELAKA, FLORIDA.**

**WHEREAS**, trees provide a setting with a variety of color unsurpassed in shade and hue, and

**WHEREAS**, trees are an invaluable psychological counterpart to the man-made urban setting, and

**WHEREAS**, trees absorb a high percentage of carbon dioxide and return oxygen, a vital ingredient to life; and

**WHEREAS**, trees are a valuable asset that can affect an area economically, and

**WHEREAS**, The Town Council of the Town of Welaka has determined that the protection of trees on public and private property within the Town of Welaka is not only desirable but essential to the present and future health, safety and welfare of all citizens,

and

**WHEREAS**, The Town of Welaka recognizes that trees on public and private property are valuable contributors to the Town's environment

**NOW, THEREFORE**, be it enacted and ordained by the Town Council of the Town of Welaka, Florida:

1. Kenneth Pagano

January 5, 2024 at 1:02:51 PM

Circumference is easier to measure in the

2. Kenneth Pagano

February 23, 2024 at 8:36:15 AM

Included Heritage Tree in definition.

3. Kenneth Pagano

January 8, 2024 at 11:04:56 AM

“trees(s) is used throughout the ordinance both for ordinary trees and Regulated Trees. Thus, use “Regulated Trees” when intended.

Section 1. Definitions

For the purpose of the administration and enforcement of this Ordinance, and unless otherwise stated in this Ordinance, the following words shall have a meaning as indicated herein:

1

(a) **Tree:** Any living self-supporting perennial plant whose one main stem attains at least a diameter of three [3] inches or nine [9] inches in circumference, at four and one-half [4.5] feet [4.5] above ground level and a height of fifteen [15] feet at maturity.

(b) **Street Trees:** Trees, shrubs, bushes and all other woody vegetation on land lying between property lines on either side of all streets, avenues or ways within the Town

(c) **Park Trees:** Trees, shrubs, bushes and all other woody vegetation in public parks having individual names, and all areas owned by the Town, or to which the public has free access as a park.

2 3

(d) **Regulated Tree:** Any living tree which is eight [8] inches or more in diameter or at least 24 two [224] feet inches in circumference, whichever dimension is lesser, at a point four and one-half [4.5] feet [44] above ground level. The definition shall include all eChampion and Heritage tTrees regardless of size. Regulated tree(s) shall hereinafter be called "tree" or "trees."

(e) **Champion Trees:** Those trees that have been identified by the Florida Division of Forestry or by the Florida Forest Service as being the largest of their species within the State of Florida or by the American Forestry Association as the largest of their species in the United States. A The current list of eChampion tTrees is shall be kept on file and will be subject to revisions and will be updated yearly at regularly scheduled public meeting of the Trees and Gardens Board with the Town of Welaka Town Tree Board.

(f) **Heritage Trees:** Any trees with that are a diameter of at least thirty [30] inches, or seven feet ten inches at least ninety four [94] inches in circumference, whichever dimension is lesser, measured at a point four and one-half [4.5] feet above ground level.

4. Kenneth Pagano

January 5, 2024 at 12:58:41 PM

Not a definition. Move to Section 7.

5. Kenneth Pagano

January 5, 2024 at 1:00:01 PM

Move to Tree Plan. This list may change often.

Taking out of ordinance and move to tree plan

allows revisions without revising the

---

4 (g) **Street Trees to be Planted:** The following list constitutes the official Street Tree species list for the Town of Welaka, Florida. No species other than those included in this list, may be planted as Street Trees without written permission of the Town Tree Board.

5 **Small Trees**

Dahoon, Holly Hop, Hornbeam, Jerusalem, Thorn Chickasaw, Plum, Bottlebrush, Pindo Palm, and Cherry Laurel

6. Kenneth Pagano

January 8, 2024 at 11:19:39AM

This is the make-up of the current tree board.

---

**Medium Trees**

Dogwood-Cabbage Palm Redbud

Golden Rain Tree American Holly Loblolly Bay Pumpkin Ash East Palatka Holly Wax Myrtle

**Large Trees**

Bald Cypress, Winded Elm, Hackberry, Red Maple, Laurel Oak, Live Oak, Washington Palm, Sycamore, Sweetgum, Date Palm.

**Section 2. Creation and Establishment of a Town Tree Board**

There is hereby created and established a Town Tree Board for the Town of Welaka, Florida, which shall consist of five (5) members; who are ~~1 council member of this Town who shall not be the chairman of the tree board, and 4~~ public citizens of the Town who shall be appointed by the Mayor of the Town, ~~one~~ of which one (1) shall be the Chairperson of the Town Tree Board, to oversee this ordinance and bring all findings and programs to the Council.

**Section 3. Term of Office of Tree Board Members**

6 The term of office and the method for filling vacancies established under ~~s~~Section 2 of this Ordinance shall be as follows: Three public citizen board members who shall be appointed in each even number year ~~and One~~two public citizens ~~and one council member~~ who shall be appointed in odd number years. Vacancies shall be filled as necessary.

**Section 4. Compensation of Tree Board Members**

Members of the Tree Board shall serve without compensation.

**Section 5. Duties and Responsibilities of Tree Board**



7. Kenneth Pagano

February 23, 2024 at 8:43:51 AM

All Regulated Trees should be considered.

8. Kenneth Pagano

January 8, 2024 at 11:33:15 AM

LEGAL

This needs more consideration. Applicant or CF determines health. Or applicant marks trees CF says are healthy. Liability issue for legal dept.

9. Kenneth Pagano

January 8, 2024 at 11:40:33 AM

See exceptions Sect 6.(c).

(a) It shall be the responsibility of the Tree Board to study, investigate, counsel, develop and/or update annually, and administer a written plan for the care, preservation, pruning, planting, replanting, removal or disposition of trees and shrubs in parks, along streets, and in other public areas. Such plan will be presented annually to the Town Council and, upon their acceptance and approval, shall constitute the official comprehensive ~~Tree~~ ~~Plan~~ for the Town;

(b) The Tree Board, when requested by the Town Council, shall consider, investigate, make findings, report and recommend upon any special matter of question coming within the scope of its work.

(c) Site plans, development plans, or subdivision plats that result in an alteration of a site, or that require Planning and Zoning approval under Town Of Welaka Land Development Plan, shall include consideration of ~~Regulated~~ ~~Tree~~ preservation; and the approval of such plans shall constitute the issuance of a tree permit consistent with the approved plan. Site plans, development plans and subdivision plats ~~may~~shall require a pre-design, on-site meeting with, ~~at minimum, one current member~~ of the town Tree Board to locate any ~~e~~Champion ~~Tree~~s or ~~h~~Heritage ~~Tree~~s.

7 8

(1) If such trees are present and there is some dispute regarding the health of such trees, the County Forester will determine the health of such trees. The applicant will mark and locate, ~~using a registered land surveyor,~~ all ~~champion trees and all heritage~~Regulated ~~Tree~~s ~~deemed healthy enough to provide substantial long-term benefits~~. The applicant may locate additional trees ~~to be preserved~~.

(2) Notice of application for ~~authorization~~a permit to remove a ~~Regulated~~ ~~Tree~~ shall be provided to the members of the Tree Board, and one or more of the members of the Tree Board shall be provided a reasonable opportunity to comment to the permitting authority prior to the issuance of a permit or conditional use permit that would authorize the removal of trees.

9

(3) A ~~subsequent~~Regulated ~~Tree~~ location survey must be included in the application. The applicant will be ~~required to save all~~ ~~e~~Champion ~~Tree~~s and Heritage Trees.

(4) Site plan approval requires the retention of a 15 percent tree canopy for all zoning districts except industrial and platted single-family subdivisions. The Town ~~Tree Board~~ may grant the application with less than 15 percent canopy if one or more of the criteria listed in Section 6 are met.

10. Kenneth Pagano

January 8, 2024 at 11:52:40 AM

How to enforce when property is not associated with a building permit. Suggestion: A sign at each Town entrance that reads "Welaka is a TreeCity" "CALL before you CUT"

11. Kenneth Pagano

January 8, 2024 at 11:59:51 AM

This would amount to an environmental impact study that the TTB may not be qualified to do. Nor could it be done within the required 5 days. Further, who bears the cost of the study. The Town's Land Development Plan should have provisions for when an environmental impact study is required.

12. Kenneth Pagano

February 23, 2024 at 8:45:27 AM

All Regulated Trees should be considered.

13. Kenneth Pagano

February 23, 2024 at 8:49:19 AM

TB feels permits for pruning would be to cumbersome for people.

10 | Section 6. Tree Permits—Generally

(a) ~~When Required.~~ In addition to the development review required under Section 455, Aa permit shall be required as a condition precedent to the removal or relocation of any ~~Champion Tree or Heritage~~Regulated Tree on any property within the CityTown limits. A ~~R~~non-regulated ~~T~~ree or other tree not considered a ~~Champion Tree or Heritage Tree that is located completely on private property~~ does not require a permit to remove or relocate.

Nothing herein should be interpreted to exempt the property owner or developer from any landscaping and buffering requirements in the Land Development Code or from any other local, State or Federal permit requirements.

(b) **Permit Process.** The following shall serve as the standard permitting process for tree removal or relocation permits in the Town of Welaka ~~not covered in Section 5.(c):~~

(1) Any ~~person wishing~~property owner or property owner's representative required to obtain a tree permit shall make application with the Building Department on such form as shall be prescribed by the Building Official. An application fee may be required, the amount of which shall be established by a resolution of the Welaka Town Council.

11

(2) The Building Official shall forward the application to ~~chairman of~~the Tree Board who shall review the applications ~~for consideration and determine what effect the removal will have upon the drainage, topography, natural resources, and ecology of the area and shall consider these factors~~ in granting or denying ~~an~~the application.

12

(3) A member of the Tree Board shall, ~~within a reasonable time after of~~the filing of an application concerning a ~~Champion Tree or Heritage~~Regulated Tree, ~~attempt to~~verify the information contained in the application and shall either approve or deny the application as to each ~~R~~Regulated ~~T~~ree proposed to be removed or relocated ~~or pruned~~. Applications that are denied may be appealed to the Welaka Town Council.

13

(c) **Permit Approval- Considerations.** The Building Official and the Tree Board shall grant the application if it finds one or more of the criteria are met:

(1)The tree ~~is an immediate~~poses safety hazard that may result in physical harm to persons, domestic animals, buildings, motor vehicle traffic, bicycle traffic, or pedestrian traffic.

14. Kenneth Pagano

January 8, 2024 at 12:08:18 PM

The County Forester would determine if an arborist is necessary.

15. Kenneth Pagano

January 5, 2024 at 12:58:41 PM

Not a definition. Moved to Section 7. See notes above concerning location of lists.

16. Kenneth Pagano

February 23, 2024 at 8:57:42 AM

Placing lists in the Tree Plan rather than in the Ordinance saves having to revise an ordinance should the list change. Revising the Tree Plan needs only simple Council approval whereas changing the Ordinance would require much more time.

(2) ~~The tree is infected with~~ exhibits an infestation of harmful insects or fungi that are not generally typically present on other trees of the species and may reasonably be expected to spread to other trees not so infested as determined by the Putnam County Arborist/County Forester.

(3) The Regulated Tree, by its location, prevents reasonable use or development of the site, and no reasonable alternative to such use or development is possible.

(4) The Regulated Tree, by the normal growth of its branches or roots, is causing progressive damage to buildings or other structures, and no reasonable correction or prevention is available other than the removal or pruning of the tree.

As a condition of the granting of a permit, the applicant may be required to relocate the trees proposed for removal or replace the removed trees with new trees planted elsewhere on the site. Replacement trees may be required on a more than one-for-one basis if the replacement trees are smaller than the tree being removed; however, replacement trees shall not be required on more than a three-for-one basis. A tree list developed as part of this ordinance shall be used as a reference for selecting replacement trees.

In all cases wherein this chapter shall require replacement of any tree, the replacement shall be made with replacement stock. "Replacement stock" is hereby defined as any tree contained on the replacement stock list having a height of at least eight [8] feet and a Florida Nursery Grade Number One or better. Survival of replacement stock will be guaranteed until the replacement stock meets with the definition of "tree" as defined in Section 1. Replacement stock may be any of the trees listed on a list of approved trees established by resolution of the Welaka Town Council

**Section 7. ~~Street Trees Species to be Planted~~ Tree Plan**

The following sections comprise the requirements and contents of the Tree Plan:

15 ~~Street Trees to be Planted:~~ The following list constitutes the official Street Tree species list for the Town of Welaka, Florida. No species other than those included in this list, may be planted as Street Trees without written permission of the Town Tree Board.

16 The official tree species list for the Town of Welaka shall be included in the Tree Plan. No other species than those in that list shall be planted as a Street Tree or Park Tree without the permission of the Tree Board. ~~No species other than those included in the street tree list may be planted as street trees without written permission of the Tree~~

17. Kenneth Pagano

February 23, 2024 at 9:00:54 AM

Spacing requirements differ among species.

Board.---

(Sections 8 thru 13 to be incorporated into Section 7 and renumber as required)

(End of first work shop discussion.)

17

**Section 8.(a) Spacing**

The spacing of street trees will be in accordance with the tree species size classes. ~~referred to in Section 8, and no trees may be planted closer together than the following:--~~

- ~~Small trees, 20 feet--~~
- ~~Medium trees, 30 feet--~~
- ~~Large trees, 50 feet, except in special plantings designed or approved by a landscape architect.--~~

**Section 9.(b) Distance from Curb and Sidewalk**

To prevent damage to sidewalks and curbs, ~~the~~ the distance trees may be planted from curbs or curb lines and sidewalks will be in accordance with the tree species size classes. ~~referred to in section 8. and no trees may be planted closer to any curb or sidewalk than the following:--~~

- ~~Small trees ----- 2 feet--~~

- ~~Medium trees-Large~~ (a)feet-
- ~~trees-~~ (b)feet-

**~~Section 10.(c)~~ Distance from Street Corners and Fire Hydrants**

No street tree shall be planted closer than twenty [20] feet of any street corner, measured from the point of nearest intersecting curbs or curb lines. No street tree shall be planted closer than fifteen [15] feet of any fire hydrant.

**(d) Call Before You Dig**

Prior to any planting, a survey of existing utilities must be performed ("call before you dig - 811") to prevent damage to said utilities.

**~~Section 11(e).~~ Public Tree Care**

1. The Town of Welaka shall have the right to plant, prune, maintain, relocate or remove trees, plants and shrubs within the lines of all public rights-of-way, streets, alleys, avenues, lanes, squares, parks and other public grounds, as may be necessary to ensure public safety or to preserve or enhance the symmetry and beauty of such public grounds.

18

2. ~~The Tree Board may remove or cause or order to be removed any tree~~ or part thereof which is in an unsafe condition or which by reason of its nature is injurious to sewers, electric power lines, gas lines, water lines or other public improvements, or is affected with an injurious fungus, insect or other pest. This section does not prohibit the planting or pruning of street trees by owners of adjacent property provided that planted trees meet the requirements and any proposed pruning of existing Street Trees or Park Tree must be approved in advance by the Tree Board.

3. All public agencies and utilities shall comply with this ordinance. All public utilities, governmental

19. Kenneth Pagano

February 23, 2024 at 9:17:05 AM

Placing lists in the Tree Plan rather than in the Ordinance saves having to revise an ordinance should the list change. Revising the Tree Plan needs only simple Council approval whereas changing the Ordinance would require much more time.

---

agencies and their subcontractors shall comply with the "National Arborist Association Standard for the Pruning of Shade Trees" when pruning trees on public or private property. Notice shall be provided to landowners at least one week in advance of pruning and/or removing landowners' trees. Emergency removal requiring immediate action to protect the health and safety of the public are not subject to this ordinance.

**Section 12(f). Tree Topping**

It shall be unlawful as a normal practice for any person, business entity, firm, corporation or Town department to top any street tree, park tree or other tree on public or private property. "Topping" is defined as the severe cutting back, of limbs to stubs larger than three [3] inches in diameter within the tree's crown to such a degree so as to remove the normal canopy and disfigure the tree. Trees severely damaged by storms or other causes, trees serving as viable habitat for wildlife, or certain trees under utility wires or other obstructions where other pruning practices are impractical may be exempt from this requirement at the determination of the Tree Board.

**Section 13(g). Pruning, Corner Clearance**

Every owner of any tree overhanging any street or right-of-way within the Town shall prune the branches so that such branches shall not obstruct the light from any streetlamp or obstruct the view of any street intersection, and to that end there shall be a clear space of eight [8] feet above the surface of the street or sidewalk. Such owners shall remove all dead, diseased or dangerous trees, or broken or decayed limbs which constitute a menace to the safety of the public. The Town shall have the right to prune any tree or shrub on private property when it interferes with the proper spread of light along the street from a streetlight, or interferes with visibility of any traffic-control device or sign.

**Section 14(h). Dead/Diseased Tree Removal on Private Property**

The Town shall have the right to cause the removal of any dead or diseased trees on private property within the Town when such trees constitute a hazard to life and property or harbor insects or disease which constitute a potential threat to other trees within the city. The Tree Board will notify in writing the owners of such trees. Removal shall be done by the owners at their own expense within thirty [30] days after the date of service of notice. In the event of failure of an owner to comply with such provisions, the Town shall have the authority to remove such trees and charge the cost of removal on the owner's property.

**19 Section 15(i). Evasive ~~Invasive~~ Trees**

The Town shall cause no planting or cultivating of ~~the following evasiveinvasive~~ plants upon public property in the Town

---

of Welaka. Furthermore; the Town strongly recommends that all Town property owners refrain from planting or cultivating said species: ~~The invasive species list shall be included in the tree plan.~~

- (a) ~~Mimosa, Silk Tree~~
- (b) ~~Woman's Tongue~~
- (c) ~~Asparagus Fern~~
- (d) ~~Orchid Tree~~
- (e) ~~Australian Pine, Beach Sheoak~~
- (f) ~~Camphor Tree~~
- (g) ~~Winged Yam~~
- (h) ~~Air Potato~~
- (i) ~~Cat's Claw Vine~~
- (j) ~~Surinam Cherry~~
- (k) ~~Laurel Fig~~
- (l) ~~Chinese Privet, Hedge Privet~~
- (m) ~~Japanese Honeysuckle~~
- (n) ~~Nandina, Heavenly Bamboo~~
- (o) ~~Popcorn Tree, Chinese Tallow Tree~~
- (p) ~~Flamegold Tree~~
- (q) ~~Bottlebrush, Weeping Bottlebrush~~
- (r) ~~Golden Bamboo~~
  - ~~Oyster Plant~~
  - ~~Simple Leaf Chaste Tree~~

- 
- (s) ~~Chinese Wisteria~~
  - (t) ~~Malanga, Elephant Ear~~

#### **Section 16(j). Protection and Preservation**

It is the intent of this section to ensure the survival of existing trees during development and alteration of a site. Recognizing the impossibility of protecting all trees, the developer will designate those trees to be preserved and the level of protection to be afforded them based on the following categories:

1. *Category I* Trees: Those trees identified during a pre-design on-site meeting as being healthy Heritage Trees which do not conflict with the approved site plan. Trees so designated will be protected from construction activities within the full drip line of the tree. All Champion Trees will be protected to Category I standards or better.
2. *Category II* Trees: Those trees identified during a pre-design meeting which are desirable to keep but due to location and development activities cannot be protected to the level of Category I Trees. Construction activities will be kept at a minimum often feet from the trunk of Category II Trees. Alternative construction techniques such as pervious pavements, jacking and boring, bridging over large roots, and root aeration systems may be used to protect these trees.
3. *Category III* Trees: Those trees which, due to number or location, cannot receive the level of protection afforded Category I and II trees, yet add to the landscape and may survive development activities.

#### **Section 178. Exemptions**

- (a) **Forestry:** All bona fide commercial forestry operations, including natural, planted, and hardwood forests, regardless of zoning or tax classifications, are exempt from this ordinance insofar as the following provision are met:
  1. **Qualifications:** Parcels in the Agriculture, Commercial or Residential Zoning classification must be ten acres or greater in size. A commercial forestry operation in the above classifications must have a forest management plan in effect similar to, and meet the same minimum standards as, the forest management plan furnished or developed by the county forester; however, one good and accepted forest management practice



---

will not be required in lieu of another.

2. **Owners** of commercial forestry operations in areas zoned Agriculture, Commercial, or Residential must submit a notice of activity to the Tree Board prior to the commencement of the following silvicultural activities: timber harvesting, mechanical site preparation, or land clearing. This notice will include the following information:

- Owner's name
- Parcel number
- Parcel acreage
- Acreage affected
- Type of activity
- Vendor name and address
- Estimated date of commencement of activity

3. All commercial forestry operations, regardless of zoning or tax classification, must be conducted in accordance with the Silviculture Best Management Practices Manual and the Management Guidelines for Forested Wetlands in Florida. Failure to comply will terminate the exemption as provided herein from this Chapter.

(b) **Agricultural:** Lands that are zoned Agricultural and that qualify for the agricultural tax exemption are exempt from this Chapter subject to the following provisions: Requirement of permits for removal of Heritage Trees in all agricultural districts, except bona fide forestry operation within fifty [50] feet of property ownership boundaries and within four hundred [400] feet of all publicly owned parks, except in bona fide forestry operations. Within Agriculture-zoned lands, a notice of activity must be submitted to the Tree Board prior to clearing new lands for agricultural use. This notice will include the following information:

- Owner's name
- Parcel number
- Acreage affected
- Type of activity
- Vendor name and address
- Estimated date of commencement of activity

(c) **Residential:** Except for Champion and Heritage Trees, trees on lots in actual single family residential use are exempt from this section.

#### Section 489. Primary Reference Work

20. Kenneth Pagano

February 23, 2024 at 9:55:36 AM

LEGAL

What is the meaning of "Liberally".

21. Kenneth Pagano

February 23, 2024 at 9:56:30 AM

LEGAL

Should the Tree Board members be issued ID Bagdes?

22. Kenneth Pagano

February 23, 2024 at 9:57:33 AM

LEGAL

Please review for accuracy and

Whenever there is a question regarding tree protection standards, consult the Florida ~~Division of Forestry~~ Forest Service Tree Protection Manual shall serve as the primary reference.

Section 4910. Applicability of Ordinance

The terms and provisions of this Chapter shall apply to all real property lying within the incorporated limits of the Town of Welaka, including publicly owned land, rights-of-way, and easements.

20 Section 2011. Article Ordinance to be Liberally Construed

This Article Ordinance shall be liberally construed in order to effectively carry out the purposes hereof, which are deemed to be in the best interests of the public health, safety and welfare of the citizens and residents of the Town. In the event this chapter conflicts with any other applicable county or state regulations on this subject matter, the more restrictive shall apply.

Section 2412. Interference with Tree Board

21 It shall be unlawful for any person to prevent, delay or interfere with the Tree Board, or any of its agents, or servants, while engaging in and about the planting, cultivating, mulching, pruning, spraying, or removing of any street trees, park trees, or trees on private property, as authorized in this ordinance.

22 Section 2213. Local Business Tax Receipt and Insurance Required

It shall be unlawful for any private person, business entity, corporation or firm to engage in the business or occupation of pruning, treating, or removing street or park trees within the Town without first applying for and procuring a Local Business License in accordance with the requirements of the town. However, no license shall be required of any public service company or City employee doing such work in the pursuit of their public service endeavors. Before any Local Business License shall be issued, each applicant shall first file evidence of possession of liability insurance in the minimum amounts of \$25,000.00 for bodily injury and \$10,000.00 property damage indemnifying the town or any person injured or damaged resulting from the pursuit of such endeavors as herein described.

Section 2314. Enforcement; Town of Welaka Code Enforcement Board

23. Kenneth Pagano

February 23, 2024 at 9:40:34 AM

For Legal:

Where is this referenced section found?

---

Any violation or alleged violation of this ordinance may be cited by Notice of Violation issued to the offending person(s) by either (1) The Town of Welaka Code Enforcement Officer; or (2) The Town of Welaka Building Official; or (3) The Town of Welaka Tree Board; or (4) the Town of Welaka Chief of Police. Upon the issuance of such citation, the same shall be forthwith referred to the Town of Welaka Code Enforcement Board for disposition in accordance with its standard and statutory procedures.

**Section 2415. Enforcement; Penalties**

1. The Town of Welaka Code Enforcement Board, upon such notification and duly noticed hearing, in the event of a finding that a violation of this ordinance has been committed, may order the violator to pay a fine in an amount specified in this section for each day the violation continues past the date set by the enforcement board for compliance or, in the case of a repeat violation, for each day the repeat violation continues, beginning with the date the repeat violation is found to have occurred by the code inspector. In addition, if the violation is a violation described in s. 162.06(4), the enforcement board shall notify the local governing body, which may make all reasonable restoration required to bring the property into compliance and charge the violator with the reasonable cost of the restoration along with the fine imposed pursuant to this section. Making such restoration does not create a continuing obligation on the part of the local governing body to make further restoration or to maintain the property and does not create any liability against the local governing body for any damages to the property if such restoration was completed in good faith. If a finding of a violation or a repeat violation has been made as provided in this part, a hearing shall not be necessary for issuance of the order imposing the fine. If, after due notice and hearing, a code enforcement board finds a violation to be irreparable or irreversible in nature, it may order the violator to pay a fine as specified in paragraph 2.
2. ~~2)(a)~~A fine imposed pursuant to this section shall not exceed \$250 per day for a first violation and shall not exceed \$500 per day for a repeat violation, and, in addition, may include all costs of restoration pursuant to subsection (1). However, if the code enforcement board finds the violation to be irreparable or irreversible in nature, it may impose a fine not to exceed \$5,000 per violation.
3. In determining the amount of the fine, if any, the enforcement board shall consider the following factors:
  1. The gravity of the violation;
  2. Any actions taken by the violator to correct the violation; and
  3. Any previous violations committed by the violator.
4. An enforcement board may reduce a fine imposed pursuant to this section.
5. A certified copy of an order imposing a fine, or a fine plus restoration costs, may be recorded in the public records and thereafter shall constitute a lien against the land on which the violation exists and upon any other real or personal property

---

owned by the violator. Upon petition to the circuit court, such order shall be enforceable in the same manner as a court judgment by the sheriffs of this state, including execution and levy against the personal property of the violator, but such order shall not be deemed to be a court judgment except for enforcement purposes. A fine imposed pursuant to this part shall continue to accrue until the violator comes into compliance or until judgment is rendered in a suit filed pursuant to this section, whichever occurs first. A lien arising from a fine imposed pursuant to this section runs in favor of the local governing body, and the local governing body may execute a satisfaction or release of lien entered pursuant to this section.

**PASSED THE FIRST READING AT REGULAR MEETING HELD: September 8, 2015 PASSED THE SECOND READING AT  
A MEETING HELD: November 10, 2015**

**ATTEST  
SIGNED**

---

Meghan E. Allmon, Town Clerk  
Jamie D. Watts, Mayor

**Approved as to form:**

---

Patrick Kennedy, Town Attorney  
Jessica Finch, Council President



## REQUEST TO SPEAK

Meeting Type: Town Council / Zoning Board / Code Board / Other

Meeting Date: 3/12/24

Name: DAVID JELTES

Address: 808 FRONT ST

City: WELAKA State FL Zip 32993

Phone: 904 392 6187 Email: DJELTES1@gmail.com

Subject Matter (One Per Request Form):

51 McCURE ST. A RESIDENTIAL PROPERTY  
BEING USED AS COMMERCIAL FOR STORAGE  
AND PARKING OF TRAILERS, BOATS ETC.

I COMPLETED THE ONLINE FORM TO  
"TELL TOWN HALL" REGARDING THIS CODE  
ISSUE A FEW WEEKS AGO, BUT CONCERNED  
NOTHING HAS BEEN DONE

Signature [Signature]

Today's Date 3/5/24



## REQUEST TO SPEAK

Meeting Type: Town Council / Zoning Board / Code Board / Other

Meeting Date: 3/12/24

Name: DAVID JELTES

Address: 808 FRONT ST

City: WELAKA State FL Zip 32193

Phone: 904 392 6187 Email: DJELTES1@gmail.com

Subject Matter (One Per Request Form):

CONCERNS ABOUT PRELIMINARY BOUNDARY MAP  
FOR FINDING OF NECESSITY, SPECIFICALLY  
THE 200 FT WIND CORRIDOR WEST OF  
3RD ST (CR 309)

Signature [Handwritten Signature]

Today's Date 3/5/24



3524 Craftsman Boulevard • Lakeland, FL • 33803  
 Tel: (863) 665-7867 • Fax: (863) 666-5649  
**Municipal Division**

Company: Town of Welaka FL  
 Location: Welaka FL  
 Attn: Tyler  
 Phone:  
 Email: [tyler@welaka-fl.gov](mailto:tyler@welaka-fl.gov)  
 From: Robert Maxwell

Date:	2-21-24
No. Pages:	1
Quote No:	22124REM3
Terms:	N30
F.O.B.:	Factory
Hudson Pump to pay freight.	Freight included

**Subject:** Gorman Rupp T4 pumps, motors, belts and sheaves

We are pleased to offer a quotation as follows:

Qty.	Description	Price Each	Delivery
1	<b>Gorman Rupp Super T Series Self Priming Centrifugal Pump</b> Package <ul style="list-style-type: none"> <li>• Model: T4A3S-B/F</li> <li>• Size 4" suction and discharge</li> <li>• Motor: 5hp, 1800rpm, 3/60/230/460V, 184T frame, Premium Efficient TEFC cast iron construction</li> <li>• Belts and sheaves</li> </ul>	<b>\$8,945.00</b>	3-4 weeks std.
<b>Quote Valid for 60 Days</b>			

With the following notes:

- 1) Belts and sheave sizes TBD once ordered and final requested pump speed is chosen.

Best Regards,  
 Robert Maxwell

**TOTAL FOR 3 PUMPS: \$26,835.00**

**St. Augustine**  
**ELECTRIC**   
**MOTOR WORKS**  
*Water - Sewer - Standby Power*

info@saemw.com • 904-829-8211 • 14 Center Street, St. Augustine, FL 32084 • staugustineelectricmotorworks.com  
 Date: 3/8/24

Job Name/Address: Town of Welaka- Randy Harris email: Rlharris1924@gmail.com

We are pleased to submit the following quote

Quantity	Description		Total
<b>3</b>	<b>Gorman Rupp T4 pump with motor, pulley, and belts - No base</b>	<b>1</b>	<b>\$ 10,500</b>
		<b>1</b>	<b>\$ 10,500</b>
		<b>1</b>	<b>\$ 10,500</b>
NOTE:	Need pulley and belt sizes before ordering		
			\$ 31,500
		Tax	EXEMPT
		Total	<b>\$ 31,500</b>

**SUBJECT TO A 2.5 % SURCHARGE FOR PAYMENT VIA CREDIT CARD**

- 1.) Quote is good for fourteen days, unless quote is requested for specific time period.
- 2.) Certificates of Insurance are available upon request. Please request in advance if job is awarded.
- 3.) If quote is accepted, please sign below, keep one copy for your records, and return the other with your signature.

Thank you for the opportunity to quote you,

PAUL BURNETT

Customer signature: \_\_\_\_\_ P.O.# \_\_\_\_\_



## Sales Quotation

Quotation Number: T97625	Quotation Date: 03/08/2024	Sales Engineer: ROBERT MAXWELL
Revision No: 1	Date Printed: 03/08/2024	Phone: (C) 863 559-3421 (O) 863-665-7867
Customer Number: 107490		rmaxwell@tencarva.com
Customer RFQ	Order Contact: CATHY JACKSON	Branch: FL LAKELAND

Document Address:  
TOWN OF WELAKA  
ATTN ACCOUNTS PAYABLE  
PO BOX 1098  
WELAKA FL 32193

Delivery Address:  
TOWN OF WELAKA  
400 4th AVENUE  
WELAKA FL 32193

Payment Terms: Net 30	Customer Contact: RANDY HARRIS
Terms of Delivery: FOB SHIPPING POINT PREPAID & ALLOW	Customer Phone: 904-907-7651
Ship Via: BEST WAY FREIGHT ALLOWED	Customer Email: RLHARRIS21@ICLOUD.COM

7-10 DAY LEAD TIME

Pos	Part No / Description	QTY	Unit	Sell Price	Ext. Sell Price
1	<b>AMT PUMP</b> . 5585-H6 , 6IN <b>ENGINE DRIVEN TRASH PUMP (HONDA V-TWIN OHV) TRAILER MOUNT</b>	1	EA	15,250.00	15,250.00

**Sub Total: 15,250.00**

**Gross Total: 15,250.00**

**TRAILER MOUNT PULL-BEHIND PUMP**

LAKELAND ADDRESS:  
HUDSON PUMP  
3524 CRAFTSMAN BLVD  
LAKELAND, FL 33803  
PHONE (863)665-7867  
FAX (863)666-5649  
CREDIT@TENCARVA.COM  
WWW.HUDSONPUMP.COM

REMIT TO BY MAIL/ONLINE:  
TENCARVA MACHINERY  
PO BOX 409897  
ATLANTA, GA 30384  
WWW.TENCARVA.COM

REMIT BY ACH:  
RECEIVING BANK: BANK OF AMERICA, N.A.  
ABA/ROUTING #: 053000196  
ACCOUNT #: 000021-208-186

EMAIL FOR REMITTANCE: PAYMENTS@TENCARVA.COM

## 6" Self-Priming Engine Driven Trash Pumps

- **Cast Aluminum Casing, Seal Plate and Bell Housing**
- **Cast Iron Adapter, Volute and Suction and Discharge Manifold**
- **Trash Type Stainless Steel Impeller**
- **Silicon Carbide Mechanical Seal and Buna-N O-Rings and Check Valve**
- **6" NPT Port Size**
- **Self-Priming to 20 Feet**
- **Engine Options: Honda V-Twin or Kohler Diesel Engine**
- **Solids Handling and Dirty Water Design**
- **Maximum Solids Handling 3"**
- **Patented Unique Slide Mechanism Permits Complete Service of Pump Without Removing Hoses or Removing Pump Components from Trailer**
- **Seal Wash Feature for Extended Seal Life**



Diesel Driven Trash Pump

The AMT 6" Engine Driven Trash Pump is designed for applications requiring high volume flow and solid/debris handling capabilities. Pumps are designed to handle liquids with solids content or dissolved solids and debris. Pump is constructed of heavy duty sand cast aluminum with cast iron and stainless steel internal parts for wear resistance and durability. **Patented built-in slide mechanism** features nylon and powder coated steel components that permit servicing, repairing and cleaning entire pump without removing hoses or pump components from trailer. Digital tachometer/hourmeter installed.

Requires 12 Volt Battery: BCI Group 24, Minimum of 500 CCA (Cold Crank Amps) Battery Box Cables Setup for Automotive Post Type Connection.

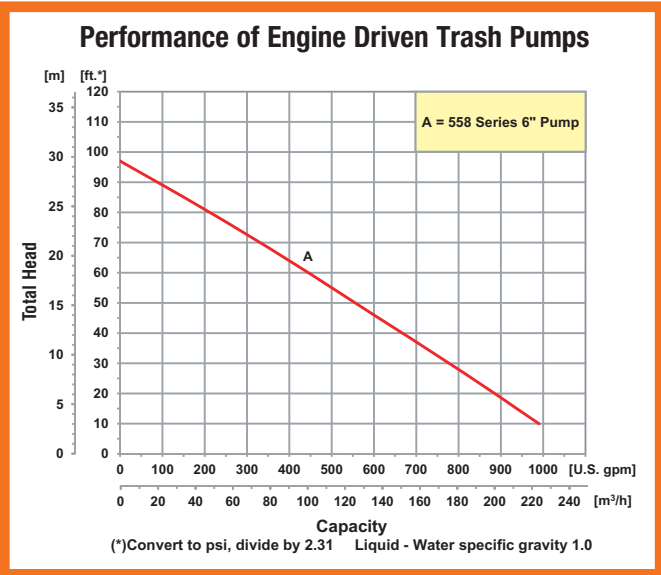

400 Spring Street • Royersford, PA 19468 USA

[www.amtpump.com](http://www.amtpump.com) • 888-amt-pump (268-7867)

For use with nonflammable liquids compatible with pump component materials. Viton® and Teflon® are registered trademarks of E. I. DuPont.



# Engine Driven Self-Priming Trash Pumps

## 6" Trash Pumps



Model	Driver	Base	Engine Type	Run Type (Hours)	Tank Size (Gal./Ltr.)	Ship Wt. (Lbs.)
5585-H6	Honda V-Twin OHV +++▲	Trailer	2 Cyl. Air Cooled	9	20 / 75.7	1,000
5586-H6	Honda V-Twin OHV +++▲	Skid	2 Cyl. Air Cooled	9	20 / 75.7	725
5587-D6	Kohler KDW1003 Diesel +++▲	Trailer	3 Cyl. Liquid Cooled	12	20 / 75.7	1,250
5588-D6	Kohler KDW1003 Diesel +++▲	Skid	3 Cyl. Liquid Cooled	12	20 / 75.7	975

**Construction: Cast Aluminum with Cast Iron and Stainless Steel Components**  
 +++ Electric Start, Requires 12V DC, BCI Group 24, MIN 500 CCA Battery (Battery Not Included)  
 ▲ Oil Alert Included

**Maximum Solids Handling Capacity: 3" Diameter**

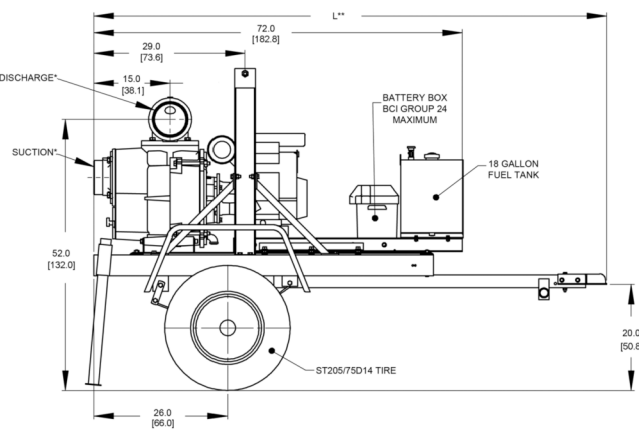
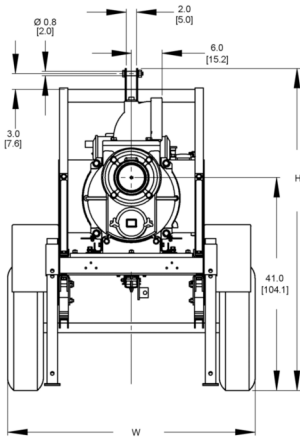

**Trailer Model**

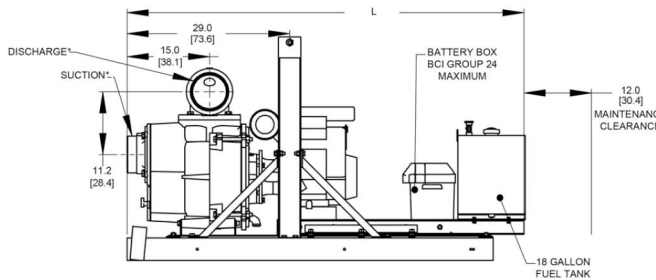
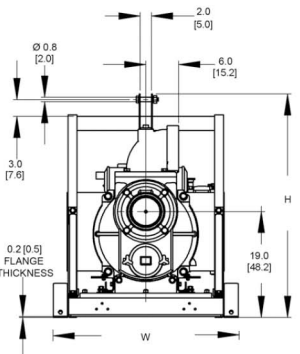

**Skid Model**

Model	HP Class ♦	SUC*	DIS*	L**	W	H
5585-H6	23	6	6	99.0 [251.4]	48.0 [121.9]	62.0 [157.4]
5586-H6	23	6	6	71.0 [180.3]	33.0 [83.8]	40.0 [101.6]
5587-D6	23	6	6	99.0 [251.4]	48.0 [121.9]	62.0 [157.4]
5588-D6	23	6	6	71.0 [180.3]	33.0 [83.8]	40.0 [101.6]

♦ HP Class represents market category and is not intended to define actual horsepower.

(\*) Standard NPT pipe thread.

(\*\*) This dimension may vary due to engine manufacturer's specifications.

NOTE: Dimensions are in inches (centimeters) and have a tolerance of ± 1/8".

## Standard Features

- Cast Aluminum with Cast Iron and Stainless Steel Components for Long Lasting Durability
- Silicon Carbide/Viton® Mechanical Seal and Buna-N O-rings and Check Valve
- Built-in Check Valve for Fast Priming to 20 Feet
- Maximum Solids Handling 3"
- 6" NPT Port Size
- Delivers up to 1,000 GPM
- Digital Tachometer/ Hourmeter Installed
- Maximum Temperature 180° F
- 12 Volt DC Electric Start
- Available in Trailer or Skid Mounted
- D.O.T. Approved Trailer— Refer to Your State and Local Codes for Registration
- Easy Cleanout and Service Features with the Unique AMT Patented Slide Mechanism
- Steel Suction Strainer and Nipple Included
- Seal Wash Feature for Extended Seal Life



**Manufacturer of AMT & IPT Pumps**

400 Spring Street • Royersford, PA 19468 USA

**www.amtpump.com • 888-amt-pump (268-7867)**

The Gorman-Rupp Company reserves the right to discontinue any model or change specifications at any time without incurring any obligation.  
 ©2012 American Machine and Tool Company. All rights reserved.



# Q U O T A T I O N

PAGE: 1

American Mower & Saw, Inc.  
3698 Winged Foot Circle  
Green Cove Springs, FL 32043  
Phone #: (386)325-3356  
Fax #: (386)325-6797

PHONE #: (904)467-9800  
CELL #: (386)546-2338  
ALT. #:  
P.O.#:  
TERMS: **Net 15 EOM**  
SALES TYPE: **Quote**

DATE: 1/17/2024  
ORDER #: 1258271  
CUSTOMER #: 10145  
CP: JL  
LOCATION: 1  
STATUS: **Active**

## BILL TO 10145

Town of Welaka  
P.O. BOX 1098  
WELAKA, FL 32193

## SHIP TO

Town of Welaka  
P.O. BOX 1098  
WELAKA, FL 32193

MFR	PRODUCT NUMBER	DESCRIPTION	QTY	PRICE	NET	TOTAL
HUS	942888	SUPER Z 72" 35HP KAW SOURCEWELL CONTRACT# 031121-HTE 7GA FABRICATED STEEL DECK, 21CC PY PUMPS WITH PARKER TG WHEEL MOTORS 14MPH, HIGHBACK SUSPENSION SEAT W/3' OF TRAVEL KAW COMMERCIAL FX ENGINE WITH 3 YEAR WARRANTY 5 YEAR/1200 HOUR OR 2 YEAR UNLIMITED HOUR WARRANTY ON MOWER FREE SETUP AND DELIVERY OF NEW MOWERS PRIORITY SERVICE IN OUR REPAIR DEPARTMENT FOR LIFE OF MACHIN	1	\$17,921.00	\$13,081.00	\$13,081.00
HUS	942813	SUPER Z 60" 27HP KAW FX850 \$17350	1	\$15,199.00	\$12,664.00	\$12,664.00

Prices reflected on this quote are valid for 30 days.

SUBTOTAL: \$25,745.00  
TAX: \$0.00  
ORDER TOTAL: **\$25,745.00**

Authorized By: \_\_\_\_\_

# SUPER Z

- ✓ 54", 60", 66" & 72" side-discharge decks
- ✓ 60" & 72" rear-discharge decks
- ✓ 27hp, 35hp & 38.5hp Kawasaki® FX engines
- ✓ 2yr / No hour limit limited warranty or 5yr / 500hr limited warranty
- ✓ Up to 14 mph



**Commercial-grade Torque**  
Hydro-Gear 21cc PY pumps  
and Parker TG310  
wheel motors.



**Heavy-duty Hydraulics**  
with 3 gal. oil reservoir, oil cooler  
w/ fan & hot oil shuttle.



**Kawasaki® FX Engines**  
FX850, FX1000, and  
FX1000EFI engine options.



**ALL PURCHASE ORDERS MUST BE MADE OUT TO (VENDOR):**

**Deere & Company**  
 2000 John Deere Run  
 Cary, NC 27513  
 FED ID: 36-2382580  
 UEID: FNSWEDARMK53

**ALL PURCHASE ORDERS MUST BE SENT TO DELIVERING DEALER:**

**Ag-Pro**  
 100 South Dancy Street  
 Hastings, FL 32145  
 904-692-1538  
 WHastingsGM@agproco.com

**Quote Summary**

**Prepared For:**  
 TOWN OF WELAKA  
 PO BOX 1098  
 WELAKA, FL 32193

**Delivering Dealer:**  
**Ag-Pro**  
 Austin Shoemaker  
 100 South Dancy Street  
 Hastings, FL 32145  
 Phone: 904-692-1538  
 ashoemaker@agproco.com

**Quote ID:** 29282841  
**Created On:** 24 July 2023  
**Last Modified On:** 24 July 2023  
**Expiration Date:** 31 December 2023

Equipment Summary	Suggested List	Selling Price	Qty	Extended
<b>JOHN DEERE 3025E Compact Utility Tractor</b> Contract: FL Ag & Lawn Equip 25101900-21-STC (PG F2 CG 22) Price Effective Date: February 16, 2023	\$ 22,167.00	\$ 18,398.61 X	1 =	\$ 18,398.61
<b>JOHN DEERE 3025E Compact Utility Tractor</b> Contract: FL Ag & Lawn Equip 25101900-21-STC (PG F2 CG 22) Price Effective Date: February 16, 2023	\$ 28,811.00	\$ 23,913.13 X	1 =	\$ 23,913.13
<b>Frontier RC2060 Lift-Type Rotary Cutter</b> Contract: FL Ag & Lawn Equip 25101900-21-STC (PG F2 CG 22) Price Effective Date: February 16, 2023	\$ 3,164.00	\$ 2,626.12 X	1 =	\$ 2,626.12
<b>Equipment Total</b>				<b>\$ 44,937.86</b>

\* Includes Fees and Non-contract items

**Quote Summary**

Equipment Total	\$ 44,937.86
Trade In	
SubTotal	\$ 44,937.86
Est. Service Agreement Tax	\$ 0.00

Salesperson : X \_\_\_\_\_

Accepted By : X \_\_\_\_\_



# Selling Equipment

Quote Id: 29282841      Customer Name: TOWN OF WELAKA

**ALL PURCHASE ORDERS MUST BE MADE OUT TO (VENDOR):**

**Deere & Company**  
 2000 John Deere Run  
 Cary, NC 27513  
 FED ID: 36-2382580  
 UEID: FNSWEDARMK53

**ALL PURCHASE ORDERS MUST BE SENT TO DELIVERING DEALER:**

**Ag-Pro**  
 100 South Dancy Street  
 Hastings, FL 32145  
 904-692-1538  
 WHastingsGM@agproco.com

## JOHN DEERE 3025E Compact Utility Tractor

Hours:

Stock Number:

Contract: FL Ag & Lawn Equip 25101900-21-STC (PG F2  
 CG 22)

Price Effective Date: February 16, 2023

Suggested List \*

\$ 22,167.00

Selling Price \*

**\$ 18,398.61**

\* Price per item - includes Fees and Non-contract items

Code	Description	Qty	List Price	Discount%	Discount Amount	Contract Price	Extended Contract Price
1357LV	3025E Compact Utility Tractor	1	\$ 21,913.00	17.00	\$ 3,725.21	\$ 18,187.79	<b>\$ 18,187.79</b>
<b>Standard Options - Per Unit</b>							
0202	United States	1	\$ 0.00	17.00	\$ 0.00	\$ 0.00	\$ 0.00
0409	English Operator's Manual and Decal Kit	1	\$ 0.00	17.00	\$ 0.00	\$ 0.00	\$ 0.00
1795	Less Loader	1	\$ 0.00	17.00	\$ 0.00	\$ 0.00	\$ 0.00
4061	Less iMatch™ Quick Hitch Category 1	1	\$ 0.00	17.00	\$ 0.00	\$ 0.00	\$ 0.00
4110	Draft Links - Flat Bar (Standard)	1	\$ 0.00	17.00	\$ 0.00	\$ 0.00	\$ 0.00
5210	15-19.5 6PR R4 Industrial	1	\$ 182.00	17.00	\$ 30.94	\$ 151.06	<b>\$ 151.06</b>
6210	25x8.50-14 6PR R4 Industrial	1	\$ 72.00	17.00	\$ 12.24	\$ 59.76	<b>\$ 59.76</b>
<b>Standard Options Total</b>			<b>\$ 254.00</b>		<b>\$ 43.18</b>	<b>\$ 210.82</b>	<b>\$ 210.82</b>
<b>Value Added Services Total</b>			<b>\$ 0.00</b>			<b>\$ 0.00</b>	<b>\$ 0.00</b>
<b>Total Selling Price</b>			<b>\$ 22,167.00</b>		<b>\$ 3,768.39</b>	<b>\$ 18,398.61</b>	<b>\$ 18,398.61</b>

## JOHN DEERE 3025E Compact Utility Tractor



JOHN DEERE



# Selling Equipment

Quote Id: 29282841

Customer Name: TOWN OF WELAKA

ALL PURCHASE ORDERS MUST BE MADE OUT TO (VENDOR):

Deere & Company  
2000 John Deere Run  
Cary, NC 27513  
FED ID: 36-2382580  
UEID: FNSWEDARMK53

ALL PURCHASE ORDERS MUST BE SENT TO DELIVERING DEALER:

Ag-Pro  
100 South Dancy Street  
Hastings, FL 32145  
904-692-1538  
WHastingsGM@agproco.com

### Equipment Notes:

Hours:

Stock Number:

Contract: FL Ag & Lawn Equip 25101900-21-STC (PG F2 CG 22)

Price Effective Date: February 16, 2023

Suggested List \*

\$ 28,811.00

Selling Price \*

\$ 23,913.13

\* Price per item - includes Fees and Non-contract items

Code	Description	Qty	List Price	Discount%	Discount Amount	Contract Price	Extended Contract Price
1357LV	3025E Compact Utility Tractor	1	\$ 21,913.00	17.00	\$ 3,725.21	\$ 18,187.79	\$ 18,187.79
<b>Standard Options - Per Unit</b>							
0202	United States	1	\$ 0.00	17.00	\$ 0.00	\$ 0.00	\$ 0.00
0409	English Operator's Manual and Decal Kit	1	\$ 0.00	17.00	\$ 0.00	\$ 0.00	\$ 0.00
1701	Factory Installed Loader with Bucket	1	\$ 6,644.00	17.00	\$ 1,129.48	\$ 5,514.52	\$ 5,514.52
4061	Less iMatch™ Quick Hitch Category 1	1	\$ 0.00	17.00	\$ 0.00	\$ 0.00	\$ 0.00
4110	Draft Links - Flat Bar (Standard)	1	\$ 0.00	17.00	\$ 0.00	\$ 0.00	\$ 0.00
5210	15-19.5 6PR R4 Industrial	1	\$ 182.00	17.00	\$ 30.94	\$ 151.06	\$ 151.06
6210	25x8.50-14 6PR R4 Industrial	1	\$ 72.00	17.00	\$ 12.24	\$ 59.76	\$ 59.76
<b>Standard Options Total</b>			<b>\$ 6,898.00</b>		<b>\$ 1,172.66</b>	<b>\$ 5,725.34</b>	<b>\$ 5,725.34</b>
<b>Value Added Services Total</b>			<b>\$ 0.00</b>			<b>\$ 0.00</b>	<b>\$ 0.00</b>
<b>Total Selling Price</b>			<b>\$ 28,811.00</b>		<b>\$ 4,897.87</b>	<b>\$ 23,913.13</b>	<b>\$ 23,913.13</b>

## Frontier RC2060 Lift-Type Rotary Cutter



Quote Provided By  
 CRYSTAL TRACTOR & EQUIPMENT -  
 HASTI  
 John Parker  
 8515 STATE ROAD 207  
 HASTINGS, FL 32145  
 email: john.parker@crystaltractor.com  
 phone: 9046923673

-- Standard Features --

-- Custom Options --



**L Series**      **L2501HST**

\*\*\* EQUIPMENT IN STANDARD MACHINE \*\*\*

**DIESEL ENGINE**  
 Mdoel # D1703-M-DI-E4-LB1  
 Direct Injection  
 Mechanical Throttle  
 3 Cyl. 100.47 cu. in.  
 + 24.8 Gross Eng. HP  
 + 23.9 Net Eng. HP  
 + 19.0 PTO HP/HST  
 @ 2200 Eng. rpm  
 12V - 490 CCA Battery  
 Charging Output 40 Amps

**DASH INSTRUMENTS**  
 Tachometer  
 Fuel Gauge  
 Temperature Gauge  
 Hour Meter

**FLUID CAPACITY**  
 Fuel Tank 10.0 gal.  
 Cooling System 6.3 qts.  
 Crankcase 6.0 qts.  
 Transmission and 6.2 gal.  
 Hydraulics  
 Front Axle 4.8 qts.

**HYDRAULICS**  
 Open Center — Gear Type  
 Tandem Pump  
 5.2 gpm Remote/3 Pt. Hitch  
 3.1 gpm for Power Steering  
 8.3 Total gpm  
 Cat I 3-point Hitch  
 At lift Point 1918 lb.  
 24" Behind 1389 lb.

**DIMENSIONS**  
 Overall Height w/ROPS 91.7"  
 Overall Length w/3pt 114.8" 4wd  
 Wheel Base 63.3"  
 Crop Clearance 13.6"

**FRONT AXLE**  
 Integral Power Steering  
 Bevel Gear, 4WD  
 Cast Iron  
 Tread Spacing, Nonadjustable

**POWER TAKE OFF**  
 Live Continuous Running with  
 Over-running Clutch  
 540 Rear PTO - 1 Speed  
 Speed - 540 @ 2106 Eng. Rpm/HST  
 SAE Std 1 3/8" Six Spline

**DRIVE TRAIN**  
 Hydrostatic Drive  
 3 Speed L-M-H  
 Multiple Wet Disc Brakes  
 Clutch - Dry Type Single  
 Stage  
 Differential Lock  
 Rear Axle - Spur Gear

**SAFETY EQUIPMENT**  
 Foldable ROPS w/ Retractable Seat  
 Belt  
 PTO Shield  
 Safety Start Switches  
 Turn Signals / Hazard Lights  
 Mechanical Wet Disc Brakes  
 Parking Brakes  
 SMV Sign  
 Electric Key Shut-off  
 Operator Presence Control System

+ Manufacturer Estimate  
**OPERATOR STATION**  
 Color Coded Controls  
 Wide Platform Steps  
 High Back Seat with Adjustable  
 Suspension  
 Tool Box  
 Cup Holder  
 Left Hand Fender Grip

**SELECTED TIRES**  
 AMR8977B & ALR8809A  
 FT TITN 27X8.50-15 R4 STL 6 BLT  
 RT TITN 15-19.5 R4 STL 6BLT

L2501HST Base Price: \$20,073.00

(1) 66" QUICK ATTACH BUCKET	\$844.00
L2248-66" QUICK ATTACH BUCKET	
(1) FRONT LOADER W/GRILL GUARD/QC	\$5,753.00
LA526-FRONT LOADER W/GRILL GUARD/QC	
<b>Configured Price:</b>	<b>\$26,670.00</b>
Sourcewell Discount:	(\$5,867.40)
<b>SUBTOTAL:</b>	<b>\$20,802.60</b>
Dealer Assembly:	\$366.67
Freight Cost:	\$750.00
PDI:	\$400.00
Dealer Final Destination Charge	\$879.00

Total Unit Price: \$23,198.27  
 Quantity Ordered: 1  
**Final Sales Price: \$23,198.27**

**Final pricing will be based upon pricing at the time of final delivery to Sourcewell members. Purchase Order Must Reflect Final Sales Price.**

To order, place your Purchase Order directly with the quoting dealer

\*Some series of products are sold out for 2022. All equipment specifications are as complete as possible as of the date on the quote. Additional attachments, options, or accessories may be added (or deleted) at the discounted price. All specifications and prices are subject to change. Taxes are not included. The PDI fees and freight for attachments and accessories quoted may have additional charges added by the delivering dealer. These charges will be billed separately. Prices for product quoted are good for 60 days from the date shown on the

Quote Provided By  
 CRYSTAL TRACTOR & EQUIPMENT -  
 HASTI  
 Karen Fugate  
 8515 STATE ROAD 207  
 HASTINGS, FL 32145  
 email: kare.fugate@crystaltractor.com  
 phone: 9049007668

-- Standard Features --

-- Custom Options --



**Kubota**

L Series

L2501HST

\*\*\* EQUIPMENT IN STANDARD MACHINE \*\*\*

**DIESEL ENGINE**

Mdoel # D1703-M-DI-E4-LB1

Direct Injection  
 Mechanical Throttle  
 3 Cyl. 100.47 cu. in.  
 + 24.8 Gross Eng. HP  
 + 23.9 Net Eng. HP  
 + 19.0 PTO HP/HST  
 @ 2200 Eng. rpm  
 12V - 490 CCA Battery  
 Charging Output 40 Amps

**HYDRAULICS**

Open Center - Gear Type  
 Tandem Pump  
 5.2 gpm Remote/3 Pt. Hitch  
 3.1 gpm for Power Steering  
 8.3 Total gpm  
 Cat I 3-point Hitch  
 At lift Point 1918 lb.  
 24" Behind 1389 lb.

**FRONT AXLE**

Integral Power Steering  
 Bevel Gear, 4WD  
 Cast Iron  
 Tread Spacing, Nonadjustable

**DRIVE TRAIN**

Hydrostatic Drive  
 3 Speed L-M-H  
 Multiple Wet Disc Brakes  
 Clutch - Dry Type Single  
 Stage  
 Differential Lock  
 Rear Axle - Spur Gear

+ Manufacturer Estimate

**DASH INSTRUMENTS**

Tachometer  
 Fuel Gauge  
 Temperature Gauge  
 Hour Meter

**FLUID CAPACITY**

Fuel Tank 10.0 gal.  
 Cooling System 6.3 qts.  
 Crankcase 6.0 qts.  
 Transmission and 6.2 gal.  
 Hydraulics  
 Front Axle 4.8 qts.

**DIMENSIONS**

Overall Height w/ROPS 91.7"  
 Overall Length w/3pt 114.8" 4wd  
 Wheel Base 63.3"  
 Crop Clearance 13.6"

**POWER TAKE OFF**

Live Continuous Running with  
 Over-running Clutch  
 540 Rear PTO - 1 Speed  
 Speed - 540 @ 2106 Eng. Rpm/HST  
 SAE Std 1 3/8" Six Spline

**SAFETY EQUIPMENT**

Foldable ROPS w/ Retractable Seat  
 Belt  
 PTO Shield  
 Safety Start Switches  
 Turn Signals / Hazard Lights  
 Mechanical Wet Disc Brakes  
 Parking Brakes  
 SMV Sign  
 Electric Key Shut-off  
 Operator Presence Control System

**OPERATOR STATION**

Color Coded Controls  
 Wide Platform Steps  
 High Back Seat with Adjustable  
 Suspension  
 Tool Box  
 Cup Holder  
 Left Hand Fender Grip

**SELECTED TIRES**

AMR8977B & ALR8809A  
 FT TITN 27X8.50-15 R4 STL 6 BLT  
 RT TITN 15-19.5 R4 STL 6BLT

L2501HST Base Price: \$20,073.00

(1) 66" QUICK ATTACH BUCKET \$844.00  
 L2248-66" QUICK ATTACH BUCKET

(1) FRONT LOADER W/GRILL GUARD/QC \$5,753.00  
 LA526-FRONT LOADER W/GRILL GUARD/QC

Configured Price: \$26,670.00

Sourcewell Discount: (\$5,867.40)

SUBTOTAL: \$20,802.60

Dealer Assembly: \$366.67

Freight Cost: \$750.00

PDI: \$400.00

Landpride BB1260 Box Blade \$906.00

Landpride RCF2060 Mower \$2,667.00

Triple Crown 7x20 10K Trailer \$6,421.00

Dealer Fee \$499.00

Total Unit Price: \$32,812.27

Quantity Ordered: 1

**Final Sales Price: \$32,812.27**

**Final pricing will be based upon pricing at the time of final delivery to Sourcewell members. Purchase Order Must Reflect Final Sales Price.**

To order, place your Purchase Order directly with the quoting dealer

\*Some series of products are sold out for 2022. All equipment specifications are as complete as possible as of the date on the quote. Additional attachments, options, or accessories may be added (or deleted) at the discounted price. All specifications and prices are subject to change. Taxes are not included. The PDI fees and freight for attachments and accessories quoted may have additional charges added by the delivering dealer. These charges will be billed separately. Prices for product quoted are good for 60 days from the date shown on the quote. All equipment as quoted is subject to availability.

# JACKSON CARPORT AND CONCRETE CO., INC

229 EAST MAIN STREET  
POMONA PARK, FLORIDA 32181  
386-546-2297

SBMCO-025 CLASS 11 (MASONRY & CONCRETE) SBCA1-060 CLASS 11 (CARPENTRY) SBSF-003 CLASS 11 (PRE-FAB BUILDING INSTALLER)

## PROPOSAL PRESENTED TO:

<b>NAME</b>	TOWN OF WELAKA (JOHN STEWART)	<b>DATE</b>	1/30/24
<b>STREET ADDRESS</b>	400 4 <sup>TH</sup> AVE WELAKA, FL 32193	<b>PHONE NUMBERS</b>	386-546-2338 jstuart@welaka-fl.gov
<b>MAILING ADDRESS</b>	PO BOX 1098 WELAKA, FL 32193	<b>TAX PARCEL #</b>	41-12-26-9200-0320-0000

WE HEREBY SUBMIT SPECIFICATIONS AND ESTIMATES FOR:

**21X30X10 TO THE RADIUS OPEN CARPORT WITH 1 BACK SIDE GABLE ON DIRT**

### INCLUDES

### DOES NOT INCLUDE

SHEET COLOR: OLD TOWN GRAY TRIM COLOR: HAWAIIAN BLUE	PERMIT
1 GABLE END ON THE BACK SIDE (1 SHEET ON BACK GABLE)	DIRT
EXTRA LONG SLEEVES FOR ADJUSTMENT	

### NOTES:

**TOTAL COST FOR JOB: \$5,850.00**

**DOWN PAYMENT \$850.00**

**BALANCE TO BE PAID IN HALVES \$5,000.00**

**FIRST PAYMENT DUE WHEN BUILDING IS ORDERED \$2,500.00**

**PAYMENT DUE WHEN JOB IS COMPLETE \$2,500.00**

### ACCEPTANCE OF PROPOSAL AS WRITTEN

The above prices, specifications and conditions are hereby accepted. Jackson Carport and Concrete co., Inc. is authorized to do the work as specified. Payment will be made as stated above.

According to Florida Construction Lien Law Section 713.001/931.37 Florida Statutes if you fail to pay your contractor you may also have a lien on your property this means if a lien is filed your property could be sold against your will to pay for labor and materials or other services that your contractor or a sub may have failed to pay, to protect yourself you should stipulate in this contract that before any payment is made your contractor is required to provide you with a written release of lien from any company.

\_\_\_\_\_  
DATE

\_\_\_\_\_  
SIGNATURE OF PROPERTY OWNER OR PERSON RESPONSIBLE FOR PAYMENT OF ABOVE STATED JOB



Dealer Palatka Dealer Phone No. 386 328 5625 Date 2/7/24  
 Customer Name \_\_\_\_\_ County \_\_\_\_\_ Tax% (Where Delivered) \_\_\_\_\_  
 Address \_\_\_\_\_ City \_\_\_\_\_ State \_\_\_\_\_ Zip \_\_\_\_\_  
 Phone: Work (\_\_\_\_) \_\_\_\_\_ Home/Cell (\_\_\_\_) \_\_\_\_\_  
 Email: \_\_\_\_\_

UNIT SIZE	W. <u>20</u>	L. (Roof) <u>31</u>	Ht. <u>11</u>	Ga. <u>14</u> <input checked="" type="checkbox"/>	<u>12</u> <input type="checkbox"/>	Retail Price
<b>NOTE: FRAME 1 FT. SHORTER THAN ROOF LENGTH</b>						<b>5935</b>
COLOR	TOP	SIDES	TRIM			Surcharge
WAINSCOT	TOP COLOR	BOTTOM COLOR			\$	Price
			<u>20x31</u>			Tax
			<u>11</u>			Surtax
			<u>close sides</u>			Price
			<u>close end</u>			Deposit (Before Tax)
						Total
						Connection Fee
						Engineering
						Runner Fee
						Additional Labor
						Balance Due:
<input type="checkbox"/>	Regular Roof	<input type="checkbox"/>	Boxed Eave Roof	<input type="checkbox"/>	Vertical Roof	
<input type="checkbox"/>	Standard Horizontal Siding	<input type="checkbox"/>	All Vertical Siding	<input type="checkbox"/>	Lap Siding	\$
<input type="checkbox"/>	Standard Roof Pitch 3/12	<input type="checkbox"/>	Custom Roof Pitch (Additional Cost) Size of Pitch:			\$
<input type="checkbox"/>	Concrete Anchors: NEW SLAB	<input type="checkbox"/>	Ground Anchors	<input type="checkbox"/>	Asphalt Anchors Labor	\$
<input type="checkbox"/>	Concrete Anchors: Existing Slab	<input type="checkbox"/>	Certified ALWAYS	<input type="checkbox"/>	Extra Labor Cost	\$
<input type="checkbox"/> Lift Required (+15' Ht) (+32'W) 6k to Bk Lull Lift for Building or Genie Lift for rollup taller than 12'						

(50% due at scheduling if beginning balance exceeds \$15K and or if building is custom-see dealer for details)

**Permit Services provided by Carports Anywhere (additional cost)**  
 \$ \_\_\_\_\_  
 \*(Carports Anywhere is ONLY licensed for building and concrete permits) (Ex. No electric/plumbing)

Building Permit:	<input type="checkbox"/>	Carports Anywhere	<input type="checkbox"/>	Customer Permit
Concrete Permit:	<input type="checkbox"/>	Carports Anywhere	<input type="checkbox"/>	Customer Permit
Existing Concrete	Was Existing Concrete Permitted? <b>YES</b> or <b>NO</b>			

Diagram

\*Underground water/power/phone lines (etc.) are the customer's responsibility.  
 \*Installed on level land (Concrete/land that is more than 3" out of level will cause additional labor charges and or payment in full of building)

**BINDING PURCHASE CONTRACT**

This purchase contract (the "Agreement") is made between Carports Anywhere Inc and \_\_\_\_\_ (the "Buyer").

Buyer agrees, after being fully educated about Carports Anywhere Inc various products, to buy, and Carports Anywhere agrees to sell, pursuant to the terms in this Agreement. The buyer has read and understands the terms of the Agreement, including the items described above and the terms listed on the attached paper of this document which terms are expressly incorporated herein by reference, as well as, any and all relevant warranty information, and agrees to be bound by the same. ( There is a 3.5% surcharge for all credit card charges with Carports Anywhere Inc ).

Customer Signature: \_\_\_\_\_ Authorized Dealer Signature: [Signature]



**Superior Sheds**  
 2323 S. Volusia Avenue  
 Orange City, FL 32763  
 877-439-7433  
 info@superiorsheds.com

Customer Order - **Feb 5, 2024**

Ship To			
Name <u>John Welaka</u>		Order # <u>1707145934899818</u>	
Install Address _____			
City _____		State <u>FL</u>	Zip Code <u>32193</u>
Email <u>john.stuart@welaka.fl.gov</u>		Phone # <u>3865462338</u>	Mobile # _____
Building Info	Size	Color	Anchoring & Site Preparation
Style: <u>Open Carport</u>	<u>20'</u> X <u>30'</u> X <u>11'</u>	Roof <u>Light Stone</u> <input type="checkbox"/>	Installation Surface: <u>Dirt</u>
Roof Style: <u>A-Frame Vertical</u>	Width <u>20'</u> Frame Length <u>30'</u> Leg Height <u>11'</u>	Trim: <u>White</u> <input type="checkbox"/>	Power Available <input type="checkbox"/>
Leg Style: <u>Standard</u>		Siding: <u>White</u> <input type="checkbox"/>	Site Ready <input type="checkbox"/>
			Jobsite Level <input type="checkbox"/>

Design Link & Notes
Design Link: <a href="https://design.superiorsheds.com/#d8ae18d2f8a18bb1b5a2d44bad4652ab">https://design.superiorsheds.com/#d8ae18d2f8a18bb1b5a2d44bad4652ab</a>

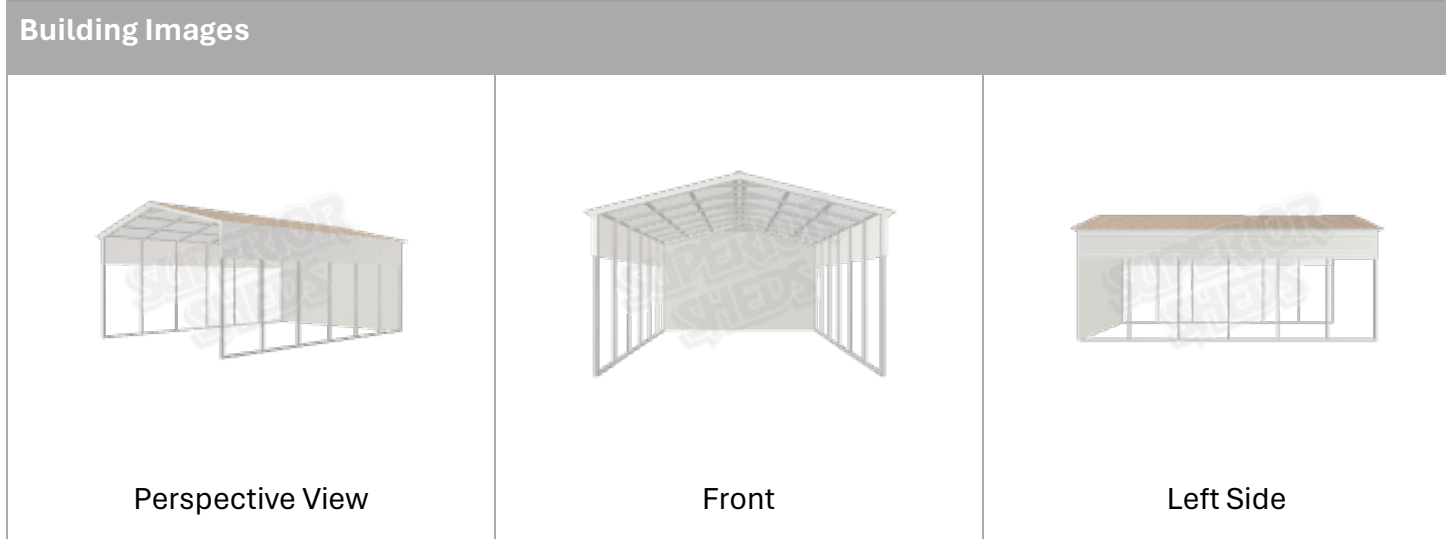

## Building Images

 Right Side	 Back		
Description		Quantity	Amount
Style: Open Carport			
Base Price: 20'x30'		1	\$5,750.00
Installation Surface: Dirt		1	-
Roof Color: Light Stone		1	-
Trim Color: White		1	-
Side Wall Color: White		1	-
End Wall Color: White		1	-
Frame Spacing: 5' OC Frame Spacing w/ 150 mph		1	-
Roof Style: A-Frame Vertical		1	-
Roof Pitch: 3/12		1	-
Leg Height: 11'		1	\$738.00
Left Side: Top - 3' Panel - J-Trim: Add J-Trim		1	\$424.00
Right Side: Top - 3' Panel - J-Trim: Add J-Trim		1	\$424.00
Back End: Fully Enclosed		1	\$2,280.00
<b>Additional Fees</b>			
Site Check		1	\$150.00
Mileage		1	\$150.00

Description	Quantity	Amount
Permits	1	\$450.00
Subtotal:		\$10,366
Sales Tax (7%):		\$725.62
Total Order Amount:		\$11,091.62
Deposit Required to Order:		\$1,663.74
Amount Due after Deposit:		\$9,427.88
*Installer Fee 12%:		\$1,110.64
35% Due at time of Manufacturing:		\$3,882.07
50% Due at time of Scheduling:		\$5,545.81

Signatures	
Customer Signature:	
Date:	
Desired Delivery Date:	
Delivery Notes:	

Dealer or Manufacturer Signature:	
Date:	

**Terms and Conditions**

Thank you for your business!

By signing above, the Customer (“you”) is entering into an agreement (this “Agreement”) with Superior Sheds, Inc. (“Superior Sheds” or “we”/“us”) for the manufacture of a custom building kit built to the specifications of the engineering plans of your building (the “Building”), effective as of the date we approve the order. You acknowledge and agree that once we have approved the order of the Building, all deposits are non-refundable. You further acknowledge and agree that payment in full is due prior to the time the Building is placed on the truck for delivery to your location by an independent contractor that you have engaged to install your Building. Superior Sheds does not install buildings or carports. The transaction date of the sale is when the Building is placed on your installer’s trailer and the Building becomes your property at that time.

All plan (drawing) requirements are set by local jurisdictions. Generic plans and letters prepared by a Professional Engineer (P.E.) are available for a fee of \$400.00. Site specific plans require a custom plan and letter (fees vary) which must be prepared by a Professional Engineer and can be provided by Superior Sheds. Customer shall pay the engineering fee in full and in advance once the engineering fee has been determined by the engineer. Custom plans and letters prepared by a Professional Engineer are nonrefundable once they have been ordered by the Customer.

Prepared By and Upon Recording Return To:  
The Law Offices of Patrick J Kennedy, PA  
PO Box 298  
Welaka, FL 32193

Inst: 202454003989 Date: 02/15/2024 Time: 3:29PM Doc Stamp-  
Deed: 14.00 By: ST, DC, Matt Reynolds, Putnam, County Page 1  
of 2 B: 1744 P: 1453

## QUITCLAIM DEED

THIS QUITCLAIM DEED, made as of the 22 day of JANUARY, 2024 and between Arlene D. Dildy, a.k.a. Arlene C. Dildy, a married woman, whose post office address is 204 Dogwood Lane, Mt. Olive, NC 28365, as "GRANTOR", and the Town of Welaka, a municipal corporation whose post office address is 400 4<sup>th</sup> Ave, Welaka, FL 32193, as "GRANTEE".

(Wherever used herein, the terms "GRANTOR" and "GRANTEE" include all the parties to this instrument and the heirs, legal representatives and assigns of individuals, and the successors and assigns of corporations.)

### WITNESSETH

THAT the GRANTOR, for and in consideration of the sum of Ten Dollars (\$10.00) and/or other valuable consideration in hand paid by the GRANTEE, the receipt and sufficiency of which is hereby acknowledged, does hereby remise, release and quit-claim unto the GRANTEE all of the rights, title, interest, claims and demands GRANTOR has in or to the following described real estate situated in Putnam County, Florida, to-wit:

Legal Description: WELAKA MB1 P51 BLK 62 E1/2 OF LOT 1 (EX BK112 P544)

Parcel Number: 41-12-26-9200-0620-0012

911 Address: 640 Palmetto St, Welaka, Florida 32193

TOGETHER WITH ALL tenements, hereditaments, easements and appurtenances thereto belonging or in anywise appertaining; and all the estate, right, title, interest, lien, equity and claim whatsoever for the said GRANTOR, either in law or equity, to the benefit of the GRANTEE;

TO HAVE AND TO HOLD in fee simple forever;

AND THAT, the above-described property is not the homestead property of the GRANTOR.



In Witness Whereof, the said GRANTOR has signed and sealed these presents on the day and year first above written:

GRANTOR:

Bettie Keel  
Witness's Signature

Arlene D. Dildy  
Arlene D. Dildy

Bettie Keel  
Witness Printed Name

Karen H Andrews  
Witness's Signature

KAREN H Andrews  
Witness Printed Name

State of NC

County of Wayne

I, the undersigned, a Notary Public in and for said County, in said State, hereby certify that Arlene D. Dildy, whose name is signed to this Quit Claim Deed, and [ ] who are known to me  produced a Driver's License (type of identification) as identification, acknowledged before me on this day that, being informed of the contents of the instrument, they, executed the same voluntarily on the day the same bears date.

Given under my hand this 22 day of Jan 2024.



Karen H Andrews  
Notary Public

My Commission Expires: 8-3-24

# TOWN OF WELAKA

## Check Register (Checks and EFTs of All Types)

Vendor IDs ARLENE to ARLENE

(Report period: February 1, 2024 to March 31, 2024)

Check Number	Date	EFT#/Vend /Invoice	Invoice Amount	Amount Paid	Credits	Discounts	Net Amount
Cash Account #3 [CCB - General Oper. 7301]							
50023	02/15/24	ARLENE PROPERTY PURCHASE	Arlene Dildy 2000.00	2000.00	0.00	0.00	2000.00
		Check Total		2000.00	0.00	0.00	2000.00
		Cash account		2000.00	0.00	0.00	2000.00
		Report Total		2000.00	0.00	0.00	2000.00

**PAYMENT RECEIPT SUMMARY**

Linda Myers  
Putnam County Tax Collector  
PO Box 1339 Palatka, FL 32177  
**DO NOT PAY**

Total Payment	7,045.61	Entry Date	02/21/2024
Location	Tax Administration	Payment Date	02/21/2024

**Payments**

Method	Check #	Paid By	Payment Amount
Check	50024	General Account Town of Welaka P O Box 1098 WELAKA FL 32193	7,045.61

**Accounts**

Receipt #	Account #	Year	Ctrl #	Cert #	Owner(s)	Type	Amount
Q02212024P012108	41-12-26-9200-0620-0012	2023	65650	-	DILDY ARLENE C	RE	702.92
Q02212024P012115	41-12-26-9200-0620-0012	2016	94299	2017-0021172	DILDY ARLENE C	RE	699.83
Q02212024P012114	41-12-26-9200-0620-0012	2017	94292	2018-0020793	DILDY ARLENE C	RE	792.04
Q02212024P012113	41-12-26-9200-0620-0012	2018	94298	2019-0022166	DILDY ARLENE C	RE	692.52
Q02212024P012112	41-12-26-9200-0620-0012	2019	65650	2020-0023378	DILDY ARLENE C	RE	1,264.14
Q02212024P012111	41-12-26-9200-0620-0012	2020	65650	2021-0019124	DILDY ARLENE C	RE	1,090.78
Q02212024P012110	41-12-26-9200-0620-0012	2021	65650	2022-0019592	DILDY ARLENE C	RE	953.68
Q02212024P012109	41-12-26-9200-0620-0012	2022	65650	2023-0019339	DILDY ARLENE C	RE	849.70

<b>Total:</b>	<b>7,045.61</b>
---------------	-----------------

# TOWN OF WELAKA

## Check Register (Checks and EFTs of All Types)

Vendor IDs PUT to PUTNAM COUNT

(Report period: February 1, 2024 to March 31, 2024)

Check Number	Date	EFT#/Vend /Invoice	Invoice Amount	Amount Paid	Credits	Discounts	Net Amount
Cash Account #3 [CCB - General Oper. 7301]							
50024	02/16/24	PUT 640 PALMETTO - TAX	*PUTNAM CO. TAX COLLECTOR 7045.61	7045.61	0.00	0.00	7045.61
		Check Total		7045.61	0.00	0.00	7045.61
		Cash account		7045.61	0.00	0.00	7045.61
		Report Total		7045.61	0.00	0.00	7045.61

(\*) One or more checks have payee names that do not match the name contained within the database record.